

حقيبة تعليمية

بعنوان:

Digital Techniques

الفصل الدراسي الأول

إعداد

التدريسي الرئيسي: أ.م.د. رشا ثابت محمد
التدريسي الثانوي: م.د. سهيل نجم عبدالله

2023 - 2022

المقدمة

التقنيات الرقمية تستخدم في العديد من الانظمة و المجالات التكنولوجية ومنها اجهزة التلفاز، انظمة الاتصالات و الرادار، انظمة كشف المواقع و التتبع، الانظمة العسكرية، الاجهزة الطبية، اجهزة السيطرة، اجهزة الحاسوب و غيرها من الأنظمة. يشير المصطلح (digital) الى نوع البيانات التي يتم التعامل معها و معالجتها داخل اجهزة الحاسوب و غيرها من الاجهزة الرقمية. الهدف الرئيسي لهذه المادة الدراسية هو تعليم الطالب اسس الدوائر المنطقية في اجهزة الحاسوب و الاجهزة الطبية الالكترونية وكيفية عملها. كما توضح المادة اساسيات بناء دوائر رقمية بسيطة باستخدام جداول الحقيقة و كيفية تحليلها و تبسيطها .

Introduction

Digital techniques are used in many systems and technological fields, including televisions, communications and radar systems, location detection and tracking systems, military systems, medical devices, control devices, computers and other systems.

The term (digital) refers to the type of data that is handled and processed within computers and other digital devices.

The main objective of this course is to teach the student the basics of logic circuits in computers and electronic medical devices and how they work. The course also explains the basics of building simple digital circuits using truth tables and how to analyze and simplify them.

فهرس المحتويات

الصفحة	الموضوع	ت
2	المقدمة - Introduction	1
4	وصف المقرر الدراسي باللغة العربية	2
10	وصف المقرر الدراسي باللغة الإنكليزية	3
18	إرشادات للطلبة	4
19	المحاضرة الأولى	5
23	المحاضرة الثانية	6
30	المحاضرة الثالثة	7
34	المحاضرة الرابعة	8
42	المحاضرة الخامسة	9
46	المحاضرة السادسة	10
49	المحاضرة السابعة	11
53	المحاضرة الثامنة	12
58	المحاضرة التاسعة	13
62	المحاضرة العاشرة	14
65	المحاضرة الحادية عشر	15
68	المحاضرة الثانية عشر	16
72	المحاضرة الثالثة عشر	17
78	المحاضرة الرابعة عشر	18
82	المحاضرة الخامسة عشر	19

وصف المقرر الدراسي

يوفر وصف المقرر هذا إيجازاً مقتضباً لأهم خصائص المقرر ومخرجات التعلم المتوقعة من الطالب تحقيقها مبرهنأ عما إذا كان قد حقق الاستفادة القصوى من فرص التعلم المتاحة. ولا بد من الربط بينها وبين وصف البرنامج.

1. المؤسسة التعليمية	كلية الرشيد الجامعة الاهلية
2. القسم العلمي / المركز	قسم هندسة تقنيات الأجهزة الطبية
3. اسم / رمز المقرر	تقنيات رقمية / DiTe240
4. أشكال الحضور المتاحة	اسبوعي - نظري + عملي
5. الفصل / السنة	سنوي - المرحلة الثانية
6. عدد الساعات الدراسية (الكلي)	120 ساعة سنويا بواقع 4 ساعات اسبوعياً
7. تاريخ إعداد هذا الوصف	2022-9-5
8. أهداف المقرر	
1-	التعرف على أسس الدوائر الالكترونية المستخدمة في أجهزة الحاسوب و الأجهزة الطبية الحديثة.
2-	التعرف على أنواع البيانات الرقمية و كيفية معالجتها و التحويل بين أنواعها.
3-	التعرف على المركبات الرقمية الأساسية و كيفية عملها.
4-	التعرف على جداول الحقيقة و طرق احتساب مخرجات الدوائر الرقمية.
5-	التعرف على طرق بناء دوائر رقمية بسيطة باستخدام جدول الحقيقة.
6-	التعرف على اساسيات العدادات الرقمية.
7-	التعرف على طرق تحويل البيانات التضامنية الى رقمية و بالعكس.

9- مخرجات المقرر وطرائق التعليم والتعلم والتقييم

أ. الأهداف المعرفية	
1.1	معرفة أسس التقنيات الرقمية من حيث أنظمة الاعداد المختلفة و طرق معالجتها و التحويل بينها.
1.2	معرفة أسس تبسيط المعادلات الرقمية بغية تبسيط الدوائر الالكترونية.
1.3	معرفة المبادئ الأساسية للتعامل مع الدوائر الرقمية و البوابات المنطقية في الأجهزة الالكترونية.
1.4	معرفة العدادات و غيرها من الدوائر الالكترونية المبنية باستخدام البوابات الرقمية.
ب. الأهداف المهاراتية الخاصة بالمقرر	
1.1	آلية تحليل الدوائر الالكترونية المبنية باستخدام البوابات المنطقية.
1.2	آلية تشخيص الأعطال في الأجهزة الالكترونية الرقمية.
1.3	آلية معالجة البيانات الرقمية.
1.4	آلية بناء الدوائر الالكترونية باقل تكلفة عن طريق تطبيق تبسيط المعادلات الرقمية.
طرائق التعليم والتعلم	
المحاضرات النظرية – المحاضرات الالكترونية – المختبرات العملية	
طرائق التقييم	
الامتحانات اليومية – درجات تقييم الواجبات البيتية – الامتحانات الفصلية – التقارير المختبرية – الامتحانات النهائية	
ج. الأهداف الوجدانية و القيمية	
1.1	زرع روح الابداع لدى الطلبة والحرص على ايجادهم حلول مبتكرة للمشاكل المختلفة.
1.2	تنمية قابلية الطلبة على العمل الجماعي كفرق فعالة ذات مخرجات فعالة.
1.3	تنمية الشعور بالمسؤولية لدى الطلبة والتهينة النفسية لتحمل المسؤولية.
1.4	تنمية قيم الحرص والمثابرة على انجاز العمل للوصول الى نتائج مرضية.
طرائق التعليم والتعلم	
- طرح الأسئلة القابلة للنقاش في الصف.	
- تحفيز الطالب على المشاركة في حل التمارين على السبورة اثناء المحاضرة.	

<ul style="list-style-type: none"> - التدريب المنهجي و الزيارات الميدانية. - تحفيز الطالب على المشاركة في الدورات و ورش العمل. - تكليف الطلبة كمجموعات لإنجاز مشاريع مصغرة تتعلق بالمادة الدراسية. 					
طرائق التقييم					
<ul style="list-style-type: none"> - تقييم الطلبة على المشاركة اليومية في الصف و منحه درجات إضافية. - متابعة الدورات و الورش و الندوات و تقديم الدعم المادي و المعنوي للطلبة المتميزين. - عمل مناقشات للمشاريع المصغرة المنجزة من الطلبة و تقييمها. 					
د. المهارات العامة و التأهيلية المنقولة (المهارات الأخرى المتعلقة بقابلية التوظيف و التطور الشخصي).					
1.	التعامل الصحيح من أجهزة الحاسوب و الأجهزة الإلكترونية الطبية.				
21.	القدرة على تصميم دوائر رقمية.				
31.	القدرة على تشخيص موقع الخطأ أو العطل عن طريق تتبع الدائرة الإلكترونية.				
41.	القدرة على العمل في قطاعات الأجهزة الإلكترونية الطبية و الحاسوب.				
-10- بنية المقرر					
الأسبوع	الساعات	مخرجات التعلم المطلوبة	اسم الوحدة او الموضوع	طريقة التعليم	طريقة التقييم
2-1	2 نظري 2 عملي	التعرف على اساسيات النظام الرقمي و البيانات بمختلف اشكالها	نظام الأرقام: الأعداد الثنائية، والأرقام الثمانية، والأرقام السداسية العشرية	المحاضرات النظرية	الاختبارات + الواجبات البيتية + المشاركة الصفية
3-4	2 نظري 2 عملي	التعرف على النظام الرقمي الثنائي بالتفصيل	الرموز الثنائية	المحاضرات النظرية + التجارب العملية	الاختبارات + الواجبات البيتية + المشاركة الصفية + التقارير العملية
5-6	2 نظري	التعرف على	البوابات المنطقية	المحاضرات	الاختبارات +

الواجبات البيتية + المشاركة الصفية + التقارير العملية	النظرية + التجارب العملية		البوابات المنطقية الأساسية التي تبني بواسطتها الدوائر الرقمية	2 عملي	
الاختبارات + الواجبات البيتية + المشاركة الصفية + التقارير العملية	المحاضرات + النظرية التجارب العملية	نظرية دي مورغان	تعلم طريقة تطبيق نظرية دي مورغان لتبسيط المعادلات المنطقية	2 نظري 2 عملي	8-7
الاختبارات + الواجبات البيتية + المشاركة الصفية + التقارير العملية	المحاضرات + النظرية التجارب العملية	قوانين و نظريات بولين	تعلم طريقة تطبيق نظريات بولين لتبسيط المعادلات المنطقية	2 نظري 2 عملي	10-9
الاختبارات + الواجبات البيتية + المشاركة الصفية + التقارير العملية	المحاضرات + النظرية التجارب العملية	الدوائر الرياضية	تعلم اساسيات الدوائر الالكترونية لإجراء الحسابات الرياضية	2 نظري 2 عملي	12-11
الاختبارات + الواجبات البيتية + المشاركة الصفية + التقارير العملية	المحاضرات + النظرية التجارب العملية	تبسيط الدوائر الرقمية	التعلم على طرق مجموع الضرب و ضرب المجموع لتبسيط الدوائر الالكترونية	2 نظري 2 عملي	15-13
الاختبارات +	المحاضرات	جدول الحقيقة الى خارطة	التعرف على تحويل	2 نظري	18-16

الواجبات البيتية + المشاركة الصفية	النظرية	كارنوف	جدول الحقيقة الى خارطة كارنوف	2 عملي	
الاختبارات + الواجبات البيتية + المشاركة الصفية + التقارير العملية	المحاضرات النظرية + التجارب العملية	القلاب المفصلي	التعرف على جهاز القلاب المفصلي بمختلف انواعه	2 نظري 2 عملي	21-19
الاختبارات + الواجبات البيتية + المشاركة الصفية + التقارير العملية	المحاضرات النظرية + التجارب العملية	العدادات الرقمية	التعرف على تفاصيل العدادات الرقمية و طرق بنائها	2 نظري 2 عملي	24-22
الاختبارات + الواجبات البيتية + المشاركة الصفية + التقارير العملية	المحاضرات النظرية + التجارب العملية	العدادات الخاصة و خزانات التزحيف	التعرف على الأنواع الخاصة من العدادات و الخزانات المستخدمة لتزحيف الاعداد لغرض اجراء العمليات الرقمية	2 نظري 2 عملي	26-25
الاختبارات + الواجبات البيتية + المشاركة الصفية + التقارير العملية	المحاضرات النظرية + التجارب العملية	التحويل الرقمي الى التناظري	التعرف على الية التحويل من النظام الرقمي المتقطع الى التناظري المستمر	2 نظري 2 عملي	28-27

الاختبارات + الواجبات البيتية + المشاركة الصفية + التقارير العملية	المحاضرات النظرية + التجارب العملية	التحويل التناظري الى الرقمي	التعرف على الية التحويل من النظام التناظري المستمر الى الرقمي المتقطع	2 نظري 2 عملي	30-29
-11 البنية التحتية للمقرر					
لا يوجد كتاب منهجي مقرر من قبل الوزارة			الكتب المقررة المطلوبة		
Thomas L. Floyd, "Digital Fundamentals", 11 th edition, Pearson Education © 2015.			المراجع الرئيسية (المصادر)		
Thomas L. Floyd and Jain, "Digital Fundamentals", 8 th edition, Pearson Education © 2006.					
لا يوجد			الكتب و المراجع التي يوصى بها (المجلات العلمية، التقارير، ...)		
https://www.readallbooks.org/book/digital-fundamentals-11th-edition/#download			المراجع الالكترونية، مواقع الانترنت		
https://smartbukites.com/wp-content/uploads/2019/08/digital-fundamentals-by-thomas-l.-floyd-8th-edition.pdf					
-12 خطة تطوير المقرر الدراسي					
1- تحفيز الطالب على الاستعانة بالوسائل التكنولوجية الحديثة في التعلم مثل استخدام البرمجيات و الانترنت. 2- تطوير قدرة الطلبة في استخدام برامج بناء و فحص الدوائر الالكترونية.					

COURSE SPECIFICATION

This Course Specification provides a concise summary of the main features of the course and the learning outcomes that a typical student might reasonably be expected to achieve and demonstrate if he/she takes full advantage of the learning opportunities that are provided. It should be cross-referenced with the program specification.

1. Teaching Institution	Al-Rasheed University College
2. University Department/Centre	Medical Instrumentations Techniques Engineering Department
3. Course title/code	Digital Techniques / DiTe240
4. Program(s) to which it contributes	Bachelors of Medical Instrumentations Techniques Engineering
5. Modes of Attendance offered	Weekly (Theory and Practical)
6. Semester/Year	Yearly/Level Two
7. Number of hours tuition (total)	120 hours (4 hours per week)
8. Date of production/revision of this specification	5-9-2022
9. Aims of the Course: the course aims to teach the students	
1- The fundamentals of electronic circuits used in computer and medical devices	
2- The types of digital data and the methods of their conversion.	
3- The main components and the method of their work.	

4- The truth tables and the methods of calculating the output from digital circuits	
5- Implementation of simple digital electronic circuits using truth table.	
6- The basics of digital counters.	
Analog to digital and digital to analog conversions.	
10• Learning Outcomes, Teaching, Learning and Assessment Method	
A- Knowledge and Understanding	
A1	Understanding the basics of numbers system and the conversion between numbers types.
A2	Understanding the basics of simplifying the electronic circuits by simplifying their equations.
A3	Understanding the basics of working with electronic circuits and logic gates.
A4	Understanding the basics of digital counters and their implementation.
B- Subject-specific skills	
B1	Analyzing the electronic circuits that are implemented using logic gates.
B2	The process of defining the errors and their sources.
B3	Processing the digital data.
B4	Implementing digital circuits with minimum number of gates.
Teaching and Learning Methods	
Theoretical lectures- Practical lectures – Practical Labs	
Assessment methods	

Daily tests – Homework – Mid and final year exams – Reports

C- Thinking Skills

C1	The skill of creativity and ensuring the way of finding new solutions.
C2	The skill of team work.
C3	The skill of taking responsibilities
C4	The skill of care and perseverance to get good results.

Teaching and Learning Methods

- Asking discussable questions in class.
- Motivating the student to participate in solving the exercises on the board during the lecture.
- Systematic training and field visits.
- Motivating students to participate in courses and workshops.
- Assigning students as groups to complete mini-projects related to the subject.

Assessment methods

- Evaluating students for their daily participation in the class and awarding them additional grades.
- Following up on courses, workshops and seminars, and providing material and moral support to outstanding students.
- Discussing and evaluating the mini-projects completed by the student.

D. General and Transferable Skills (other skills relevant to employability and personal development)

D1	Correct handling of computers and medical electronic devices.
D2	Ability to design digital circuits.

D3	The ability to diagnose the location of the fault or malfunction by tracing the electronic circuit.				
D4	The ability to work in the sectors of medical electronic devices and computers.				
11. Course structure					
Week	Hours	ILOs	Unit/Module or Topic Title	Teaching Method	Assessment Method
1st-2nd	2T+2 P	Learn the basics of the digital system and data in its various forms	Number system: Binary numbers, Octal numbers, Hexadecimal numbers.	Theoretical lectures	Tests + homework + class participation
3rd-4th	2T+2 P	Learn about the binary digital system in details.	Binary codes.	Theoretical & practical lectures	Tests + homework + class participation + practical reports
5th-6th	2T+2 P	Identify the basic logic gates by which digital circuits are built	Logic gates.	Theoretical & practical lectures	Tests + homework + class participation + practical

					reports
7 th -8 th	2T+2 P	Learn how to apply de Morgan's theorem to simplify rational equations	De Margan's theorems.	Theoretica l & practical lectures	Tests + homework + class participatio n + practical reports
9 th -10 th	2T+2 P	Learn how to apply Boleyn's theorems to simplify Boolean equations	Laws and theorem of Boolean algebra.	Theoretica l & practical lectures	Tests + homework + class participatio n + practical reports
11 th - 12 th	2T+2 P	Learn the basics of electronic circuits to perform mathematical calculations	Arithmetic circuit.	Theoretica l & practical lectures	Tests + homework + class participatio n + practical reports
13 th - 15 th	2T+2 P	Learning on the methods of the sum of the	Simplifying logic circuits: fundamentals	Theoretica l & practical	Tests + homework + class

		multiplication and the multiplication of the sum to simplify the electronic circuits	products, sum of products, algebraic simplification.	lectures	participation + practical reports
16 th - 18 th	2T+2 P	Learn how to convert a truth table into a Karnaugh map	Truth table to Karnaugh map.	Theoretical lectures	Tests + homework + class participation
19 th - 21 st	2T+2 P	Learn the different types of Flip-Flop	Flip Flop: RS, RST, JK, D, FF.	Theoretical & practical lectures	Tests + homework + class participation + practical reports
22 nd - 24 th	2T+2 P	Learn about the details of digital meters and how to build them	Counters.	Theoretical & practical lectures	Tests + homework + class participation

					practical reports
25 th - 26 th	2T+2 P	Identify the special types of counters and tanks used to crawl numbers for the purpose of performing digital operations	Special counters and shift registers.	Theoretical & practical lectures	Tests + homework + class participation + practical reports
27 th - 28 th	2T+2 P	Learn about the conversion mechanism from intermittent digital to continuous analog	Digital to analogue conversion.	Theoretical & practical lectures	Tests + homework + class participation + practical reports
29 th - 30 th	2T+2 P	Learn about the conversion mechanism from continuous	Analogue to digital conversion.	Theoretical & practical lectures	Tests + homework + class participation +

	analog to digital intermittent		practical reports
12. Infrastructure			
Required reading:	<ul style="list-style-type: none"> • CORE TEXTS • COURSE MATERIALS • OTHER 	<ul style="list-style-type: none"> - Thomas L. Floyd, “Digital Fundamentals”, 11th edition, Pearson Education © 2015. - Thomas L. Floyd and Jain, ““Digital Fundamentals”, 8th edition, Pearson Education © 2006. 	
Special requirements (include for example workshops, periodicals, IT software, websites)		https://www.readallbooks.org/book/digital-fundamentals-11th-edition/#download https://smartbukites.com/wp-content/uploads/2019/08/digital-fundamentals-by-thomas-l.-floyd-8th-edition.pdf	
Community-based facilities (include for example, guest Lectures , internship , field studies)		---	
13. Plan of improving the subject			
<ol style="list-style-type: none"> 1- Motivating the student to use modern technological means in learning, such as using software and the Internet. 2- Develop students' ability to use programs for building and checking electronic circuits. 			

إرشادات للطلبة

- الرغبة والحماس للتعليم
- كن مشاركاً في جميع الأنشطة
- احترم أفكار المدرس والزملاء
- أنقد أفكار المدرس والزملاء بأدب إن كانت هناك حاجة.
- احرص على استثمار الوقت
- تقبل الدور الذي يسند إليك في المجموعة
- حفز أفراد مجموعتك في المشاركة في النشاطات
- احرص على بناء علاقات طيبة مع المدرس والزملاء أثناء المحاضرة
- احرص على ما تعلمته في المحاضرة وطبقه في الميدان .
- ركز ذهنك بالتعليم و احرص على التطبيق المباشر
- تغلق الموبايل قبل الشروع بالمحاضرة

المحاضرة الأولى - الزمن: 90 دقيقة

1st week : Number system: Binary numbers, Octal numbers, Hexadecimal numbers.

أهداف المحاضرة الأولى:

يتوقع في نهاية الجلسة أن يكون الطالب قادراً على:

1. Know the types of numbers.
2. Know the methods of representing different types of numbers.
3. Converting binary, octal, hexadecimal to decimal numbers.

موضوعات المحاضرة الأولى:

1. Types of number systems
2. Representation of Numbers

الأساليب والأنشطة والوسائل التعليمية

م	الأساليب والأنشطة التدريبية	الوسائل التدريبية
1	<ul style="list-style-type: none">• نشاط التعارف• محاضرة• مناقشة• سؤال وجواب	<ul style="list-style-type: none">• جهاز حاسوب• جهاز عرض• سبورة• اوراق واقلام

خطة إجراءات تنفيذ المحاضرة الأولى

المحاضرة	الإجراءات	الزمن بالدقيقة
الأولى	الترحيب بالطلبة والتعارف معهم	90 دقيقة
	التعريف بالمصادر المعتمدة للمادة الدراسية	
	التعريف باهداف المحاضرة واهميتها	
	القاء المادة العلمية وفتح باب النقاش	
	حل امثلة وتكليف الطلبة بالواجبات	

Number Systems: Binary, Octal, and Hexadecimal

The number systems subject is a very important topic in digital techniques because it gives the basics of the types of data and their processing in digital technology and devices. This lecture presents the basics of decimal, binary, octal, and hexadecimal numbers.

Lecture objectives

At the end of this lecture, the student should be able to:

- 1- Know the types of numbers.
- 2- Know the methods of representing different types of numbers.
- 3- Converting binary, octal, hexadecimal to decimal numbers.

Types of number systems

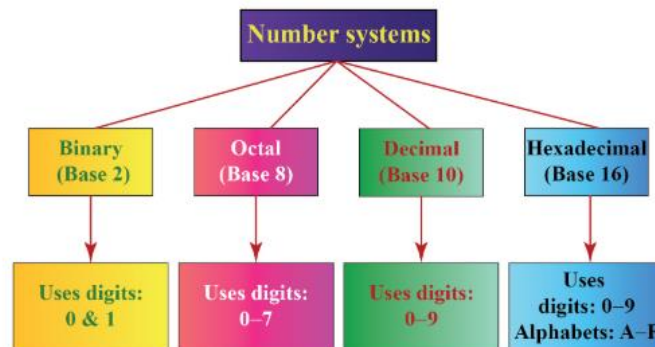

Decimal numbers

This system is composed of 10 numbers or symbols, these 10 symbols are:

0	1	2	3	4	5	6	7	8	9
---	---	---	---	---	---	---	---	---	---

These symbols are called digits.

The decimal system, also called base-10 system, because it has 10 digits which is a naturally result of the fact that man has 10 fingers. The decimal numbers can be integer or fractional.

Example decimal numbers: $(9485)_{10}$, $(34.234)_{10}$, $(100234)_{10}$

Binary numbers

In this system there are only two symbols or possible digit values that are: 0 and 1. These symbols are called binary numbers and the system called base-2 system.

Example binary numbers: $(101101)_2$, $(11011.010)_2$

Octal numbers

In this system there are 8 numbers or symbols that are:

0	1	2	3	4	5	6	7
---	---	---	---	---	---	---	---

These symbols are called octal numbers and the system called base-8 system.

Example octal numbers: $(675)_8$, $(563.43)_8$



Exercise (Lecture 01)

Represent the following numbers as you learned in this lecture and convert them to their decimal form:

- 1- $(8304.27)_{10}$
- 2- $(11101.011)_2$
- 3- $(34.27)_8$
- 4- $(AD8.C)_{16}$

المحاضرة الثانية - الزمن: 90 دقيقة

2nd week : Number system: Binary numbers, Octal numbers, Hexadecimal numbers.

أهداف المحاضرة الثانية:

يتوقع في نهاية الجلسة أن يكون الطالب قادراً على:

1. Convert decimal numbers to binary, octal, and hexadecimal.
2. Convert octal to binary and vice versa.
3. Convert hexadecimal to binary and vice versa.

موضوعات المحاضرة الثانية:

1. Conversion of decimal numbers to other types
2. Conversion of octal numbers to binary and vice versa
3. Conversion of hexadecimal numbers to binary and vice versa

الأساليب والأنشطة والوسائل التعليمية

م	الأساليب والأنشطة التدريسية	الوسائل التدريسية
1	<ul style="list-style-type: none">• نشاط التعارف• محاضرة• مناقشة• سؤال وجواب	<ul style="list-style-type: none">• جهاز حاسوب• جهاز عرض• سبورة• اوراق واقلام

خطة إجراءات تنفيذ المحاضرة الثانية

الزمن بالدقيقة	الإجراءات	المحاضرة
90 دقيقة	<ul style="list-style-type: none">الترحيب بالطلبةمراجعة سريعة للمادة الدراسية السابقة + اختبارالتعريف باهداف المحاضرة واهميتهاالقاء المادة العلمية وفتح باب النقاشحل امثلة وتكليف الطلبة بالواجبات	الثانية

Example: Convert the decimal number $(36)_{10}$ to binary.

Division by 2	Quotient	Remainder
$36 \div 2$	18	0 (LSB)
$18 \div 2$	9	0
$9 \div 2$	4	1
$4 \div 2$	2	0
$2 \div 2$	1	0
$1 \div 2$	0	1 (MSB)

$$(36)_{10} = (100100)_2$$

Example: Convert the decimal number $(39.5)_{10}$ to binary.

Division by 2	Quotient	Remainder
$39 \div 2$	19	1 (LSB)
$19 \div 2$	9	1
$9 \div 2$	4	1
$4 \div 2$	2	0
$2 \div 2$	1	0
$1 \div 2$	0	1 (MSB)
Multiplication by 2		
0.5×2	1	0
0×2	0	

$$(39.5)_{10} = (100111.10)_2$$

Conversion of decimal to octal number

To convert the decimal number to octal, divide the number by 8 (the base) until the value is 0. When the number is fractional number, the numbers after point are multiplied by 8.

Example: Convert the decimal number $(266)_{10}$ to octal.

Division by 8	Quotient	Remainder
$266 \div 8$	33	2 (LSB)
$33 \div 8$	4	1
$4 \div 8$	0	4 (MSB)

$$(266)_{10} = (412)_8$$

Example: Convert the decimal number $(20.75)_{10}$ to octal.

Division by 8	Quotient	Remainder
$20 \div 8$	2	4 (LSB)
$2 \div 8$	0	2 (MSB)
0.75×8	6	0

$$(20.75)_{10} = (24.6)_8$$

Conversion of decimal to hexadecimal number

To convert the decimal number to hexadecimal, divide the number by 16 (the base) until the value is 0. When the number is fractional number, the numbers after point are multiplied by 16.

Example: Convert the decimal number $(423)_{10}$ to hexadecimal.

Division by 16	Quotient	Remainder
$423 \div 16$	26	7 (LSB)
$26 \div 16$	1	10 \Rightarrow A
$1 \div 16$	0	1 (MSB)

$$(423)_{10} = (1A7)_{16}$$

Conversion of octal numbers to binary and vice versa

The following subsections present the method of converting octal numbers to their binary form and the reverse.

Conversion of octal to binary number

The conversion from octal to binary is performed by converting each octal digit to its 3-bit binary equivalent as shown in the following table.

Octal	0	1	2	3	4	5	6	7
Binary	000	001	010	011	100	101	110	111

Example: Convert the octal number $(472)_8$ to binary.

Octal	4	7	2
Binary	100	111	010

$$(472)_8 = (100111010)_2$$

Conversion of binary to octal number

The conversion from binary to octal is performed as follows:

Step1: Group the binary digits into 3's starting at least significant digit (if the number of bits is not evenly divisible by 3, then add 0's at the most significant end).

Step 2: Write the equivalent octal number to each group.

Example: Convert the binary number $(10101110)_2$ to octal.

Binary	10	101	110
Octal	2	5	6

$$(10101110)_2 = (256)_8$$

Example: Convert the decimal number $(177)_{10}$ to its 8-bit binary equivalent by first converting to octal.

Division by 8	Quotient	Remainder
$177 \div 8$	22	1 (LSB)
$22 \div 8$	2	6
$2 \div 8$	0	2 (MSB)

$$(177)_{10} = (261)_8$$

Octal	2	6	1
Binary	10	110	001

$$(177)_{10} = (10110001)_2$$

Conversion of hexadecimal numbers to binary and vice versa

The following subsections present the method of converting hexadecimal numbers to their binary form and the reverse.

Conversion of hexadecimal to binary number

The conversion from octal to binary is performed by converting each octal digit to its 4-bit binary equivalent as shown in the following table.

Hexadecimal	Binary	Hexadecimal	Binary
0	0000	8	1000
1	0001	9	1001
2	0010	A	1010
3	0011	B	1011
4	0100	C	1100
5	0101	D	1101
6	0110	E	1110
7	0111	F	1111

Example: Convert the octal number $(39C8)_{16}$ to binary.

Hexadecimal	3	9	C	8
Binary	0011	1001	1100	1000

$$(39C8)_{16} = (0011100111001100)_2$$

Conversion of binary to hexadecimal number

The conversion from binary to hexadecimal is performed as follows:

Step1: Group the binary digits into 4's starting at least significant digit (if the number of bits is not evenly divisible by 4, then add 0's at the most significant end).

Step 2: Write the equivalent octal number to each group.

Example: Convert the binary number $(1001111001110000)_2$ to hexadecimal.

Binary	1001	1110	0111	0000
Hexadecimal	9	E	7	0

$$(1001111001110000)_2 = (9E70)_{16}$$

Example: Convert the binary number $(1111110100011)_2$ to hexadecimal.

Binary	1	1111	1010	0011
Hexadecimal	1	F	A	3

$$(1111110100011)_2 = (1FA3)_{16}$$

Exercise

Answer the following questions:

- 1- Convert the following numbers to decimal: $(641)_8$, $(10011101)_2$, $(24CE)_{16}$
- 2- Convert $(3117)_{10}$ to hexadecimal, then from hexadecimal to binary.
- 3- Convert $(1001011110110101)_2$ to hexadecimal.
- 4- Convert $(3527)_8$ to hexadecimal.

المحاضرة الثالثة - الزمن: 90 دقيقة

3rd week : Binary codes.

أهداف المحاضرة الثالثة:

يتوقع في نهاية الجلسة أن يكون الطالب قادراً على:

1. Convert decimal numbers to BCD.
2. Convert from BCD to decimal.
3. Convert binary to Gray code and vice versa.
4. Know the basics of ASCII codes.

موضوعات المحاضرة الثالثة:

1. BCD Basics
2. Gray code basics
3. ASCII code basics

الأساليب والأنشطة والوسائل التعليمية

م	الأساليب والأنشطة التدريسية	الوسائل التدريسية
1	<ul style="list-style-type: none">• نشاط التعارف• محاضرة• مناقشة• سؤال وجواب	<ul style="list-style-type: none">• جهاز حاسوب• جهاز عرض• سبورة• اوراق واقلام

خطة إجراءات تنفيذ المحاضرة الثالثة

الزمن بالدقيقة	الإجراءات	المحاضرة
90 دقيقة	<ul style="list-style-type: none">الترحيب بالطلبةمراجعة سريعة للمادة الدراسية السابقة + اختبارالتعريف بأهداف المحاضرة وأهميتهاالقاء المادة العلمية وفتح باب النقاشحل امثلة وتكليف الطلبة بالواجبات	الثالثة

Binary Codes

This lecture presents the method of expressing decimal numbers using binary coded decimal (BCD). The lecture also presents the basics of Gray code and ASCII code.

Lecture objectives

At the end of this lecture, the student should be able to:

- 1- Convert decimal numbers to BCD.
- 2- Convert from BCD to decimal.
- 3- Convert binary to Gray code and vice versa.
- 4- Know the basics of ASCII codes.

BCD Basics

If each digit of a decimal number is represented by its binary equivalent, this produces a code called binary-coded-decimal (BCD). Since a decimal digit can be as large as 9, 4-bits are required to code each digit. The table below shows each decimal digit and its binary equivalent.

Decimal	0	1	2	3	4	5	6	7	8	9
BCD	00 00	00 01	00 10	00 11	01 00	01 01	01 10	01 11	10 00	10 01

Conversion of decimal to BCD and vice versa

To convert the decimal number to BCD, the equivalent of each decimal number is taken from the above table.

Example: Convert the decimal numbers $(35)_{10}$, $(98)_{10}$, $(170)_{10}$, $(2469)_{10}$ to BCD.

Decimal number	BCD
35	0011 0101
98	1001 1000
170	0001 0111 0000
2469	0010 0100 0110 1001

Example: Convert the BCD codes to decimal $(10000110)_2$, $(001101010001)_2$, $(1001010001110000)_2$

BCD	Decimal number
1000 0110	86
0011 0101 0001	351
1001 0100 0111 0000	9470

Gray code basics

Gray code is unweighted and is not an arithmetic code; that is, there are no specific weights assigned to the bit positions. The important feature of the gray code is that it exhibits only a single bit change from one code word to the next in sequence.

Decimal	Binary	Gray Code	Decimal	Binary	Gray Code
0	0000	0000	8	1000	1100
1	0001	0001	9	1001	1101
2	0010	0011	10	1010	1111
3	0011	0010	11	1011	1110
4	0100	0110	12	1100	1010
5	0101	0111	13	1101	1011
6	0110	0101	14	1110	1001
7	0111	0100	15	1111	1000

Conversion of binary to Gray code

The steps are as follows:

1. The most significant bit (left-most) in the Gray code is the same as the corresponding MSB in the binary number.
2. Going from left to right, add each adjacent pair of binary code bits to get the next Gray code bit. Discard carries.

Example: Convert the binary number $(10110)_2$ to Gray code.

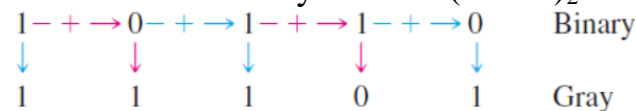

Conversion of Gray code to binary

The steps are as follows:

1. The most significant bit (left-most) in the binary code is the same as the corresponding bit in the Gray code.
2. Add each binary code bit generated to the Gray code bit in the next adjacent position. Discard carries.

Example: Convert the Gray code (11011) to binary number.

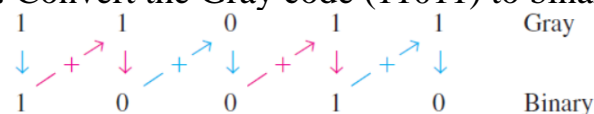

ASCII code basics

ASCII is the abbreviation for American Standard Code for Information Interchange. Pronounced “askee,” ASCII is a universally accepted alphanumeric code used in most computers and other electronic equipment. Most computer keyboards are standardized with the ASCII. When you enter a letter, a number, or control command, the corresponding ASCII code goes into the computer. ASCII has 128 characters and symbols represented by a 7-bit binary code. Actually, ASCII can be considered an 8-bit code with the MSB always 0. This 8-bit code is 00 through 7F in hexadecimal. The first thirty-two ASCII characters are nongraphic commands that are never printed or displayed and are used only for control purposes. The following table presents the ASCII codes for different numbers, characters, symbols, and commands.

Decimal - Binary - Octal - Hex – ASCII
Conversion Chart

Decimal	Binary	Octal	Hex	ASCII	Decimal	Binary	Octal	Hex	ASCII	Decimal	Binary	Octal	Hex	ASCII	Decimal	Binary	Octal	Hex	ASCII
0	00000000	000	00	NUL	32	00100000	040	20	SP	64	01000000	100	40	@	96	01100000	140	60	`
1	00000001	001	01	SOH	33	00100001	041	21	!	65	01000001	101	41	A	97	01100001	141	61	a
2	00000010	002	02	STX	34	00100010	042	22	"	66	01000010	102	42	B	98	01100010	142	62	b
3	00000011	003	03	ETX	35	00100011	043	23	#	67	01000011	103	43	C	99	01100011	143	63	c
4	00000100	004	04	EOT	36	00100100	044	24	\$	68	01000100	104	44	D	100	01100100	144	64	d
5	00000101	005	05	ENQ	37	00100101	045	25	%	69	01000101	105	45	E	101	01100101	145	65	e
6	00000110	006	06	ACK	38	00100110	046	26	&	70	01000110	106	46	F	102	01100110	146	66	f
7	00000111	007	07	BEL	39	00100111	047	27	'	71	01000111	107	47	G	103	01100111	147	67	g
8	00001000	010	08	BS	40	00101000	050	28	(72	01001000	110	48	H	104	01101000	150	68	h
9	00001001	011	09	HT	41	00101001	051	29)	73	01001001	111	49	I	105	01101001	151	69	i
10	00001010	012	0A	LF	42	00101010	052	2A	*	74	01001010	112	4A	J	106	01101010	152	6A	j
11	00001011	013	0B	VT	43	00101011	053	2B	+	75	01001011	113	4B	K	107	01101011	153	6B	k
12	00001100	014	0C	FF	44	00101100	054	2C	,	76	01001100	114	4C	L	108	01101100	154	6C	l
13	00001101	015	0D	CR	45	00101101	055	2D	-	77	01001101	115	4D	M	109	01101101	155	6D	m
14	00001110	016	0E	SO	46	00101110	056	2E	=	78	01001110	116	4E	N	110	01101110	156	6E	n
15	00001111	017	0F	SI	47	00101111	057	2F	/	79	01001111	117	4F	O	111	01101111	157	6F	o
16	00010000	020	10	DLE	48	00110000	060	30	0	80	01010000	120	50	P	112	01110000	160	70	p
17	00010001	021	11	DC1	49	00110001	061	31	1	81	01010001	121	51	Q	113	01110001	161	71	q
18	00010010	022	12	DC2	50	00110010	062	32	2	82	01010010	122	52	R	114	01110010	162	72	r
19	00010011	023	13	DC3	51	00110011	063	33	3	83	01010011	123	53	S	115	01110011	163	73	s
20	00010100	024	14	DC4	52	00110100	064	34	4	84	01010100	124	54	T	116	01110100	164	74	t
21	00010101	025	15	NAK	53	00110101	065	35	5	85	01010101	125	55	U	117	01110101	165	75	u
22	00010110	026	16	SYN	54	00110110	066	36	6	86	01010110	126	56	V	118	01110110	166	76	v
23	00010111	027	17	ETB	55	00110111	067	37	7	87	01010111	127	57	W	119	01110111	167	77	w
24	00011000	030	18	CAN	56	00111000	070	38	8	88	01011000	130	58	X	120	01111000	170	78	x
25	00011001	031	19	EM	57	00111001	071	39	9	89	01011001	131	59	Y	121	01111001	171	79	y
26	00011010	032	1A	SUB	58	00111010	072	3A	:	90	01011010	132	5A	Z	122	01111010	172	7A	z
27	00011011	033	1B	ESC	59	00111011	073	3B	;	91	01011011	133	5B	[123	01111011	173	7B	{
28	00011100	034	1C	FS	60	00111100	074	3C	<	92	01011100	134	5C	\	124	01111100	174	7C	
29	00011101	035	1D	GS	61	00111101	075	3D	=	93	01011101	135	5D]	125	01111101	175	7D	}
30	00011110	036	1E	RS	62	00111110	076	3E	?	94	01011110	136	5E	^	126	01111110	176	7E	~
31	00011111	037	1F	US	63	00111111	077	3F	?	95	01011111	137	5F	_	127	01111111	177	7F	DEL

Exercise (Lecture 03)

Answer the following questions:

- 1- Convert $(10011101)_2$ to Gray code.
- 2- Convert Gray code 10101111 to binary.
- 3- How many bits are there in the ASCII code and what is the value of the MSB.
- 4- Determine the ASCII codes and their related hexadecimal numbers for your first name.

المحاضرة الرابعة - الزمن: 90 دقيقة

4th week : Binary codes.

أهداف المحاضرة الرابعة:

يتوقع في نهاية الجلسة أن يكون الطالب قادراً على:

1. Know the NOT, AND, and OR gates.
2. Know the NAND and NOR gates.
3. Know the EX-OR and EX-NOR gates.

موضوعات المحاضرة الرابعة:

1. NOT Gate
2. AND Gate
3. OR Gate
4. NAND Gate
5. NOR Gate
6. EX-OR Gate
7. EX-NOR Gate

الأساليب والأنشطة والوسائل التعليمية

م	الأساليب والأنشطة التدريبية	الوسائل التدريبية
1	<ul style="list-style-type: none">• نشاط التعارف• محاضرة• مناقشة• سؤال وجواب	<ul style="list-style-type: none">• جهاز حاسوب• جهاز عرض• سبورة• اوراق واقلام

خطة إجراءات تنفيذ المحاضرة الرابعة

الزمن بالدقيقة	الإجراءات	المحاضرة
90 دقيقة	<ul style="list-style-type: none">الترحيب بالطلبةمراجعة سريعة للمادة الدراسية السابقة + اختبارالتعريف باهداف المحاضرة واهميتهاالقاء المادة العلمية وفتح باب النقاشحل امثلة وتكليف الطلبة بالواجبات	الرابعة

Logic Gates

This lecture presents the basics of logic gates which are used in implementing the integrated circuits (ICs). The ICs are used in many digital techniques applications therefore it is necessary to understand the basics of its components. Logic gates are primarily implemented electronically using diodes or transistors, but can also be constructed using electromagnetic relays (relay logic), fluidic logic, pneumatic logic, optics, molecules, or even mechanical elements.

Lecture objectives

At the end of this lecture, the student should be able to:

- 1- Know the NOT, AND, and OR gates.
- 2- Know the NAND and NOR gates.
- 3- Know the EX-OR and EX-NOR gates.

NOT Gate

The NOT gate is an electronic circuit that produces an inverted version of the input at its output. It is also known as an inverter. If the input variable is A, the inverted output is known as NOT A. This is also shown as A', or A with a bar over the top, as shown at the outputs. The symbol, truth table, equation, and operation are shown below.

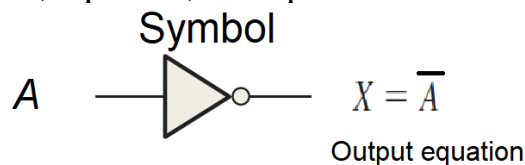

Inverter truth table.

Input	Output
LOW (0)	HIGH (1)
HIGH (1)	LOW (0)

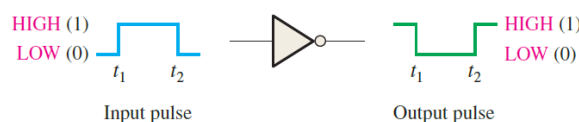

Example: Determine the output of the inverter for the input waveform shown below.

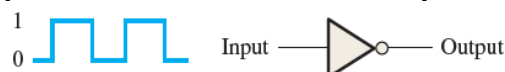

Solution:

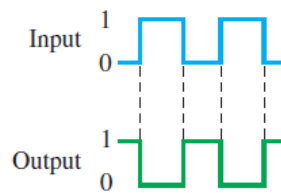

AND Gate

The AND gate is an electronic circuit that gives a high output (1) only if all its inputs are high. A dot (.) is used to show the AND operation i.e. $A.B$. Bear in mind that this dot is sometimes omitted i.e. AB . The symbol, truth table, equation, and operation are shown below.

Symbol

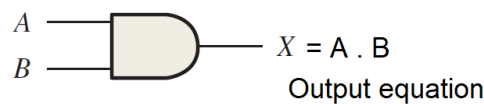

Truth table for a 2-input AND gate.

Inputs		Output
A	B	X
0	0	0
0	1	0
1	0	0
1	1	1

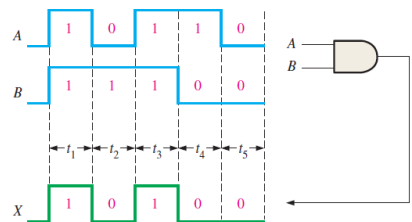

Example: Determine the output of the AND gate for the input waveforms shown below.

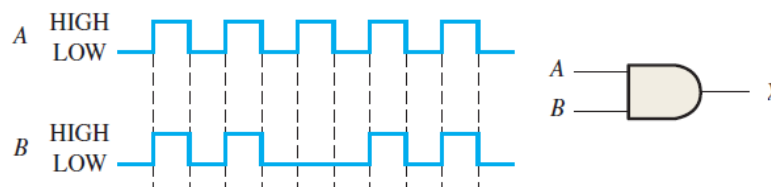

Solution:

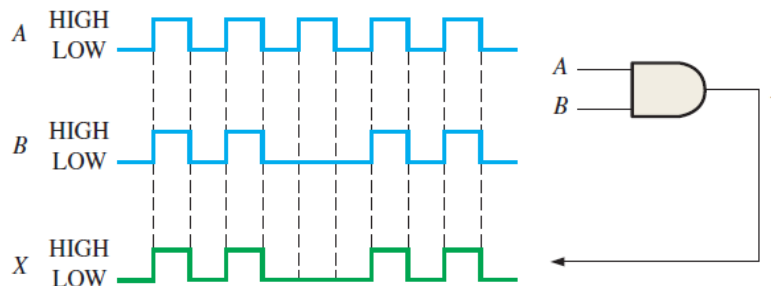

OR Gate

The OR gate is an electronic circuit that gives a high output (1) if one or more of its inputs are high. A plus (+) is used to show the OR operation. The symbol, truth table, equation, and operation are shown below.

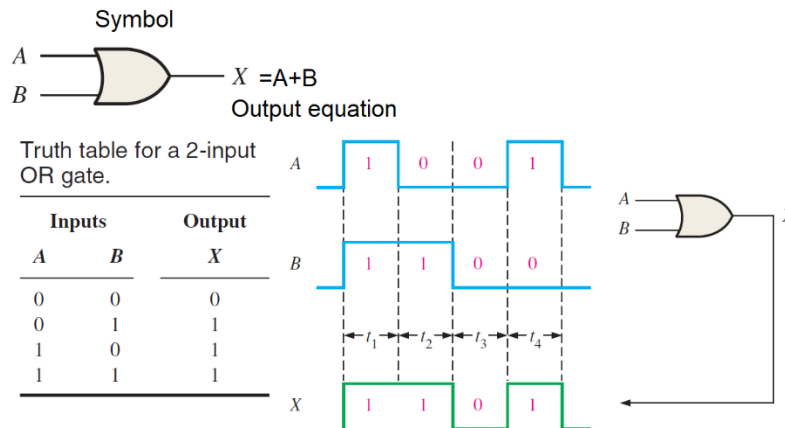

Example: Determine the output of the OR gate for the input waveforms shown below.

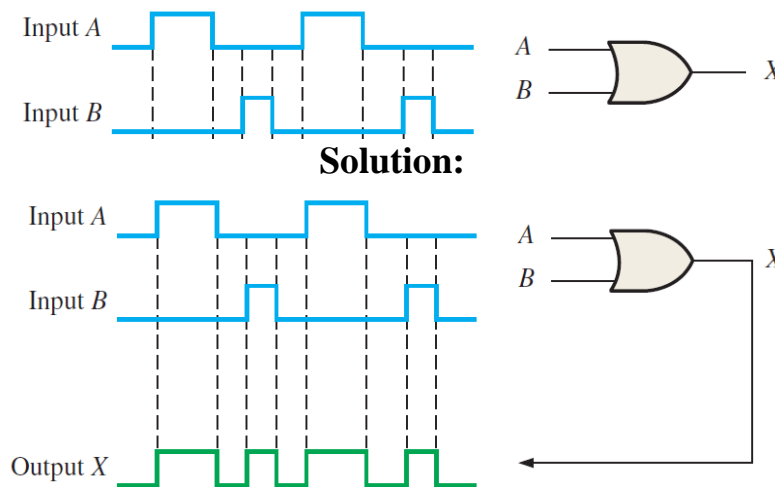

NAND Gate

This is a NOT-AND gate which is equal to an AND gate followed by a NOT gate. The outputs of all NAND gates are high if any of the inputs are low. The symbol is an AND gate with a small circle on the output. The small circle represents inversion. The symbol, truth table, and equation are shown below.

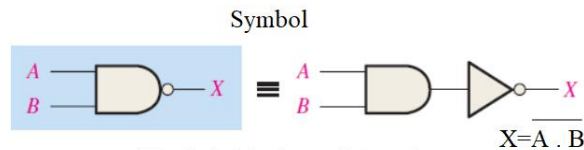

Truth table for a 2-input NAND gate.

Inputs		Output
A	B	X
0	0	1
0	1	1
1	0	1
1	1	0

Example: Determine the output of the NAND gate for the input waveforms shown below.

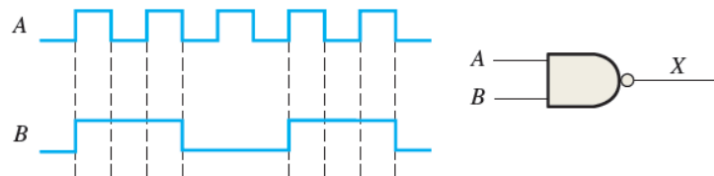

Solution:

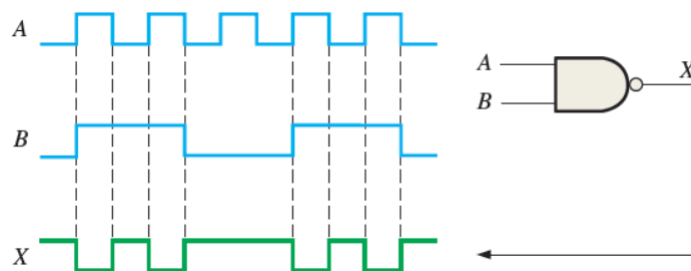

NOR Gate

This is a NOT-OR gate which is equal to an OR gate followed by a NOT gate. The outputs of all NOR gates are low if any of the inputs are high. The symbol is an OR gate with a small circle on the output. The small circle represents inversion. The symbol, truth table, and equation are shown below.

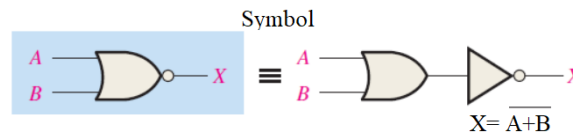

Truth table for a 2-input NOR gate.

Inputs		Output
A	B	X
0	0	1
0	1	0
1	0	0
1	1	0

Example: Determine the output of the NOR gate for the input waveforms shown below.



Solution:

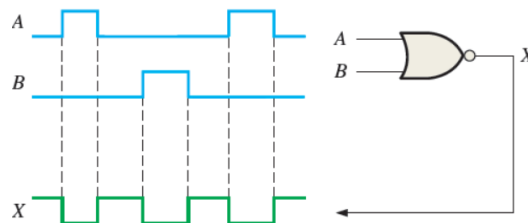

EX-OR Gate

The “Exclusive-OR” gate is a circuit which will give a high output if either, but not both, of its two inputs are high. The symbol, truth table, and equation are shown below.

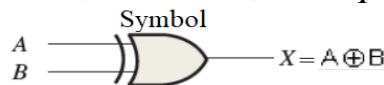

Truth table for an exclusive-OR gate.

Inputs		Output
A	B	X
0	0	0
0	1	1
1	0	1
1	1	0

EX-NOR Gate

The 'Exclusive-NOR' gate circuit does the opposite to the EX-OR gate. It will give a low output if either, but not both, of its two inputs are high. The symbol is an EX-OR gate with a small circle on the output. The small circle represents inversion.

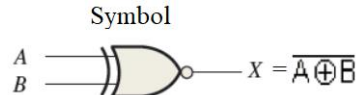

Truth table for an exclusive-NOR gate.

Inputs		Output
A	B	X
0	0	1
0	1	0
1	0	0
1	1	1

Example: Determine the output waveforms for the EX-OR gate and for the XE-NOR gate, given the input waveforms, A and B as shown below.

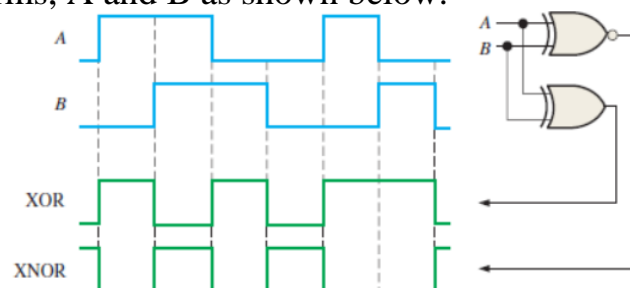



Exercise (Lecture 04)

Answer the following questions:

- 1- When 1 is on the input of an inverter, what is the output?
- 2- When is the output of an AND gate HIGH?
- 3- Describe the truth table for a 5-input AND gate.
- 4- When is the output of an OR gate LOW?
- 5- Describe the truth table for a 3-input OR gate.
- 6- When is the output of a NAND gate HIGH?
- 7- When is the output of a NOR gate LOW?
- 8- What are the logic gates that can be used to detect when the two bits are different?

المحاضرة الخامسة - الزمن: 90 دقيقة 5th week : Logic gates.

أهداف المحاضرة الخامسة:

يتوقع في نهاية الجلسة أن يكون الطالب قادراً على:

1. Determine the output expression for the logic circuit.
2. Implementing the logic circuit from its Boolean expressions.

موضوعات المحاضرة الخامسة:

1. Describing logic circuits algebraically
2. Implementing circuits from Boolean expressions

الأساليب والأنشطة والوسائل التعليمية

م	الأساليب والأنشطة التدريسية	الوسائل التدريسية
1	<ul style="list-style-type: none">• نشاط التعارف• محاضرة• مناقشة• سؤال وجواب	<ul style="list-style-type: none">• جهاز حاسوب• جهاز عرض• سبورة• اوراق واقلام

خطة إجراءات تنفيذ المحاضرة الخامسة

الزمن بالدقيقة	الإجراءات	المحاضرة
90 دقيقة	<p>الترحيب بالطلبة</p> <p>مراجعة سريعة للمادة الدراسية السابقة + اختبار</p> <p>التعريف بأهداف المحاضرة وأهميتها</p> <p>القاء المادة العلمية وفتح باب النقاش</p> <p>حل امثلة وتكليف الطلبة بالواجبات</p>	الخامسة



Logic circuits description

Any logic circuit, no matter how complex, may be completely described using the Boolean operations that are related to its logic gates. On the other side, the logic circuits can be implemented from their Boolean expressions.

Lecture objectives

At the end of this lecture, the student should be able to:

- 1- Determine the output expression for the logic circuit.
- 2- Implementing the logic circuit from its Boolean expressions.

Describing logic circuits algebraically

The output expression of the logic circuit can be described by following the sequence of the inputs in the logic gates and describing their outputs.

Example: Determine the output expression for the logic circuits shown below:

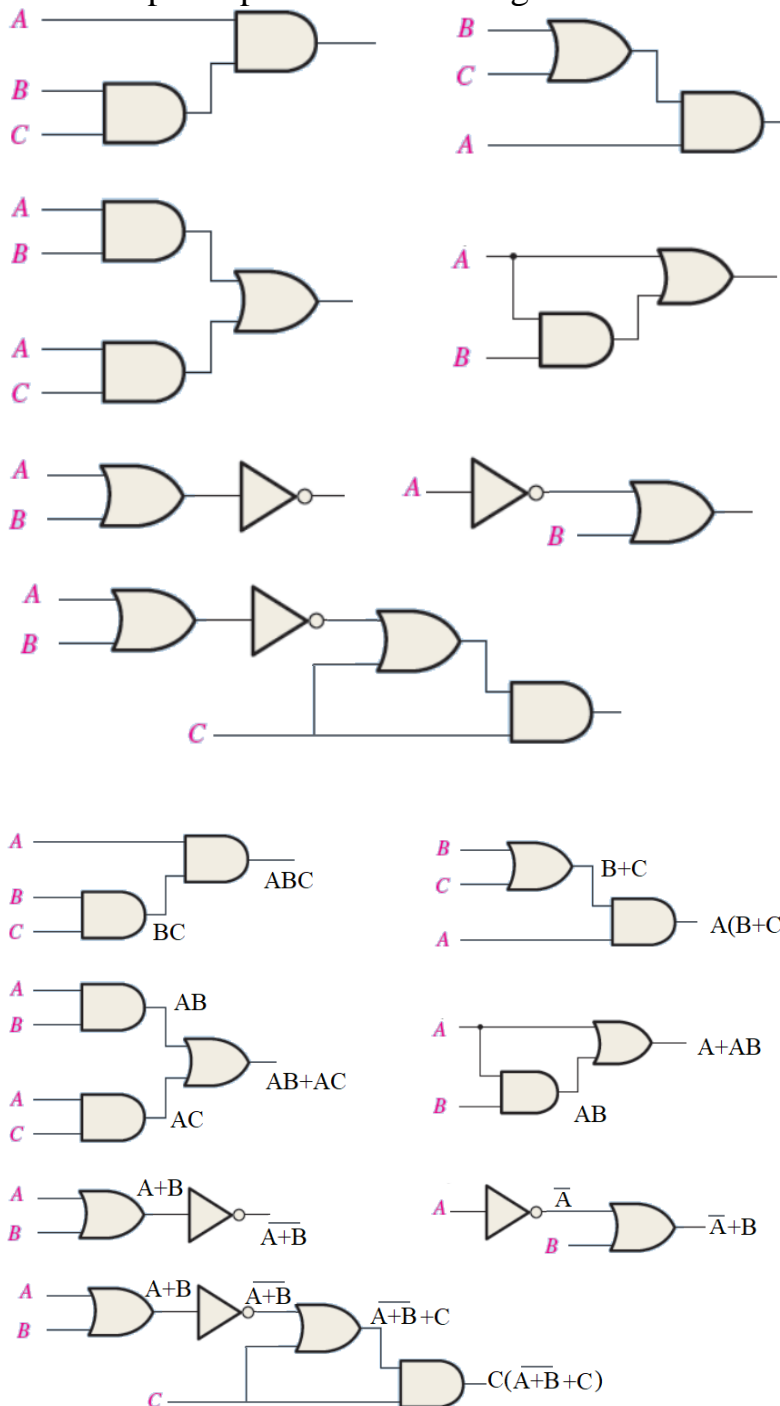

Implementing circuits from Boolean expressions

If the operation of a circuit is defined by a Boolean expression, a logic-circuit can be implemented directly from that expression.

Example: Implement the logic circuits defined by the following Boolean expressions:

- A) $AB + \bar{B}C$
- B) $AC + B\bar{C} + \bar{A}BC$
- C) $C + (\bar{A} + \bar{B} + C)$

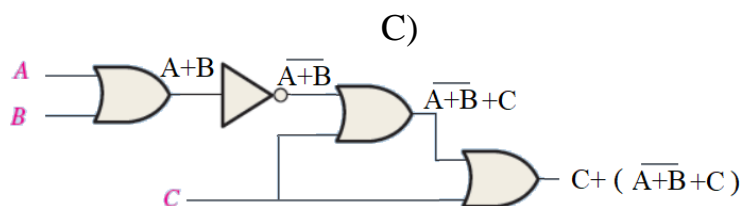
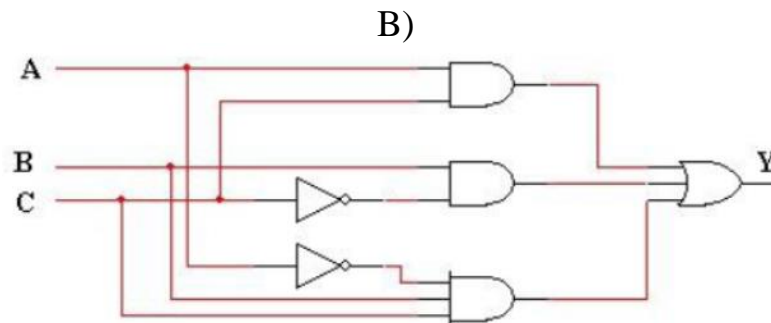
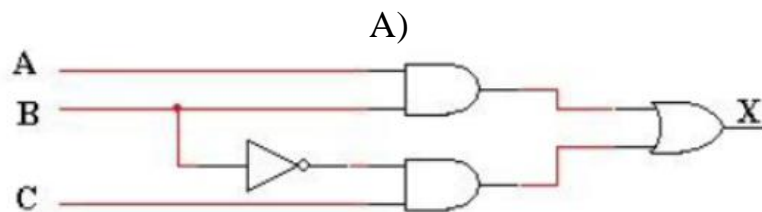

Exercise (Lecture 05)

Determine the output expression for the following circuit, and determine the output at $A=1, B=0, C=1,$ and $D=1$.

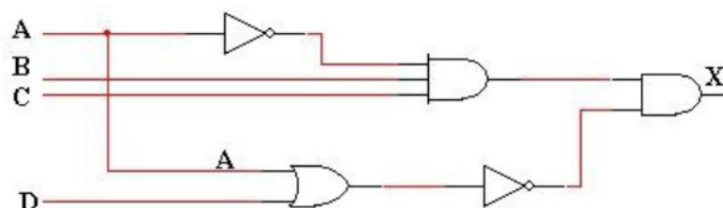

المحاضرة السادسة - الزمن: 90 دقيقة 6th week : Logic gates.

أهداف المحاضرة السادسة:

يتوقع في نهاية الجلسة أن يكون الطالب قادراً على:

1. Identify faulty logic gate in the logic circuit.
2. Answer the self-test questions that are included in this lecture.

موضوعات المحاضرة السادسة:

1. Identifying the faulty logic gate

الأساليب والأنشطة والوسائل التعليمية

م	الأساليب والأنشطة التدريسية	الوسائل التدريسية
1	<ul style="list-style-type: none">• نشاط التعارف• محاضرة• مناقشة• سؤال وجواب	<ul style="list-style-type: none">• جهاز حاسوب• جهاز عرض• سبورة• اوراق واقلام

خطة إجراءات تنفيذ المحاضرة السادسة

الزمن بالدقيقة	الإجراءات	المحاضرة
90 دقيقة	<ul style="list-style-type: none">الترحيب بالطلبةمراجعة سريعة للمادة الدراسية السابقة + اختبارالتعريف بأهداف المحاضرة وأهميتهاالقاء المادة العلمية وفتح باب النقاشحل امثلة وتكليف الطلبة بالواجبات	السادسة

Logic gates test

This lecture explains the method of identifying the faulty logic gates followed by self-test questions that are related to the logic gates and logic circuits topics.

Lecture objectives

At the end of this lecture, the student should be able to:

- 1- Identify faulty logic gate in the logic circuit.
- 2- Answer the self-test questions that are included in this lecture.

Identifying the faulty logic gate

The faulty logic gate is the one that gives wrong output. To identify the faulty logic gate, the right output must be determined and compared with the current output.

Example: Examine the following logic gates and identify the faulty logic gates.

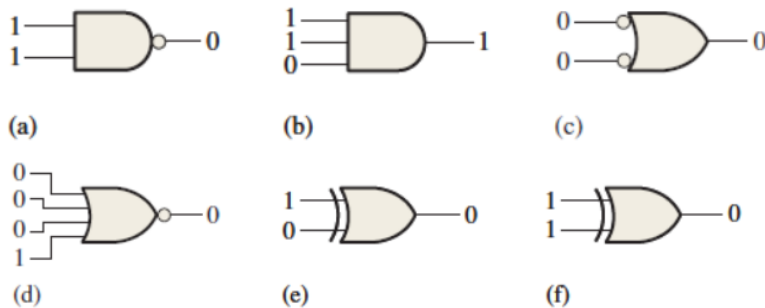

	Right output	Current output	Gate status
a	$(1.1) = \bar{1} = 0$	0	Active
b	$(1.1.0) = 0$	1	Faulty
c	$(\bar{0} + \bar{0}) = 1 + 1 = 1$	0	Faulty
d	$(\bar{0} + \bar{0} + \bar{0} + \bar{1}) = \bar{1} = 0$	0	Active
e	$1 \oplus 0 = 1$	0	Faulty
f	$1 \oplus 1 = 0$	0	Active

Self-Test

True or False

No.	Sentence	T or F
1	An inverter performs a NOT operation.	
2	A NOT gate cannot have more than one input.	
3	If any input to the OR gate is zero, the output is zero.	
4	If all the inputs to an AND gate are 1, the output is 0.	
5	A NAND gate can be considered as an OR gate followed by a NOT gate.	
6	A NOR gate can be considered as an OR gate followed by an inverter.	
7	The output of an EX-OR is 0 if the inputs are	

	opposite.	
8	The output of an EX-NOR is 0 if the inputs are opposite.	
9	OR gate is considered faulty when the inputs are both zeros while the output is 1.	
10	The equation of AND gate output for two inputs A and B is $(A+B)$.	

Choose the correct answer:

1- When the input to an inverter is LOW (0), the output is ... (a) HIGH or 0 (b) LOW or 0 (c) HIGH or 1 (d) LOW or 1
2- An inverter performs an operation known as ... (a) Complementation (b) Assertion (c) Inversion (d) both answers (a) and (c)
3- The output of an AND gate with inputs A, B and C is 0 (LOW) when ... (a) $A = 0, B = 0, C = 0$ (b) $A = 0, B = 1, C = 1$ (c) both answers (a) and (b)
4- The output of an OR gate with inputs A, B and C is 0 (LOW) when ... (a) $A = 0, B = 0, C = 0$ (b) $A = 0, B = 1, C = 1$ (c) both answers (a) and (b)
5- A pulse is applied to each input of a 2-input NAND gate. One pulse goes HIGH at $t=0$ and goes back LOW at $t=1$ ms. The other pulse goes HIGH at $t=0.8$ ms and goes back LOW at $t=3$ ms. The output pulse can be described as follows: (a) It goes LOW at $t = 0$ and back HIGH at $t = 3$ ms. (b) It goes LOW at $t = 0.8$ ms and back HIGH at $t = 3$ ms. (c) It goes LOW at $t = 0.8$ ms and back HIGH at $t = 1$ ms. (d) It goes LOW at $t = 0.8$ ms and back LOW at $t = 1$ ms.

المحاضرة السابعة - الزمن: 90 دقيقة 7th week : De Morgan's theorems.

أهداف المحاضرة السابعة:

يتوقع في نهاية الجلسة أن يكون الطالب قادراً على:

1. Know the Boolean expression in sum-of-products form.
2. Know the Boolean expression in product-of-sums form.

موضوعات المحاضرة السابعة:

1. Boolean algebra
2. Terms in Boolean expressions
3. Boolean addition
4. Boolean multiplication
5. Sum-of-Products
6. Product-of-Sums

الأساليب والأنشطة والوسائل التعليمية

م	الأساليب والأنشطة التدريسية	الوسائل التدريسية
1	<ul style="list-style-type: none">• نشاط التعارف• محاضرة• مناقشة• سؤال وجواب	<ul style="list-style-type: none">• جهاز حاسوب• جهاز عرض• سبورة• اوراق واقلام

خطة إجراءات تنفيذ المحاضرة السابعة

الزمن بالدقيقة	الإجراءات	المحاضرة
90 دقيقة	<ul style="list-style-type: none">الترحيب بالطلبةمراجعة سريعة للمادة الدراسية السابقة + اختبارالتعريف باهداف المحاضرة واهميتهاالقاء المادة العلمية وفتح باب النقاشحل امثلة وتكليف الطلبة بالواجبات	السابعة

Boolean Operations and Expressions

The form of the Boolean expression does determine how many logic gates are used, what type of gates needed, and how they are connected together. The more complex an expression, the more complex the gate circuit will be. There are also certain forms of Boolean expression that are more commonly used than others, the two most important of these are the sum-of-products and the product-of-sums forms.

Lecture objectives

At the end of this lecture, the student should be able to:

- 1- Know the Boolean expression in sum-of-products form.
- 2- Know the Boolean expression in product-of-sums form.

Boolean algebra

The Boolean algebra term refers to the mathematics of digital logic. In order to study and analyze the logic circuits, the basics of Boolean algebra must be known. The following sections present some important terms that are used in Boolean expressions followed by the basics of sum-of-products and the product-of-sums forms of Boolean expressions.

Terms in Boolean expressions

Variable, *complement*, and *literal* are terms used in Boolean algebra, the following table explains their definitions.

Term	Definition
Variable	An italic letter or word used to represent an action, a condition, or data. Any single variable can have only a 1 or a 0 value.
Complement	Is the inverse of a variable and is indicated by a bar over the variable (overbar). The complement of the variable A is read as “not A” or “A bar.”
Literal	A literal is a variable or the complement of a variable.

Boolean addition

Boolean addition is equivalent to the OR operation. Some examples of sum terms are $A + B$, $A + \bar{B}$, $A + B + \bar{C}$, and $\bar{A} + B + C + \bar{D}$. A sum term is equal to 1 when one or more of the literals in the term are 1. A sum term is equal to 0 only if each of the literals is 0.

Example: Determine the values of A, B, C , and D that make the sum term

$$A + \bar{B} + C + \bar{D} = 0.$$

Solution: $A + \bar{B} + C + \bar{D} = 0 + \bar{1} + 0 + \bar{1} = 0$

$A = 0, B = 1, C = 0, \text{ and } D = 1.$

Boolean multiplication

Boolean multiplication is equivalent to the AND operation. Some examples of sum terms are AB , $A\bar{B}$, $AB\bar{C}$, and $\bar{A}BC\bar{D}$. A sum term is equal to 1 only when each of the literal in the term is 1. A sum term is equal to 0 when one or more of the literals are 0.

Example: Determine the values of A, B, C , and D that make the product term $A\bar{B}C\bar{D} = 1$

Solution: $A\bar{B}C\bar{D} = 1\bar{0}1\bar{0} = 1$

$A = 1, B = 0, C = 1, \text{ and } D = 0.$

Sum-of-Products

Recall that a sum in Boolean algebra is the same as OR function, so a sum-of-products expression is two or more AND functions ORed together. For instance, $AB+CD$ is a sum-of-products expression.

Example: $A\bar{B}C + A\bar{D}$, $ABC + DEF$

A sum-of products form can also contain a term with a single variable, such as $A + BCD + EFG$.

Example: Draw the logic circuit for the Boolean expression: $A\bar{B}C + A\bar{D}$

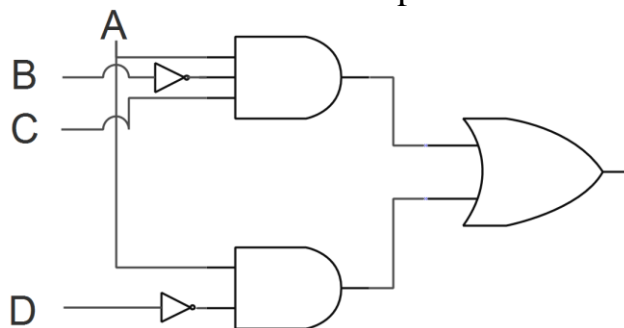

Product-of-Sums

The product-of-sums form can be thought of as the dual of the sum-of-products. It is, in terms of logic functions, the AND of two or more OR functions. For instance, $(A + B)(B + C)$ is a product-of-sum expression

Example: $(A + B)(B + C + D)$, $(A + B + C)(D + E + F)$

A product-of-sums expression can also contain a single variable term such as $A(B + C + D)(E + F + G)$.

Example: Draw the logic circuit for the Boolean expression: $A(B + C + D)(E + F + G)$.

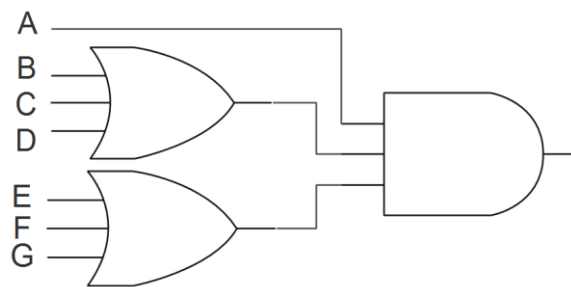

Exercise (Lecture 07)

Answer the following:

- 1- Determine the values of $A, B,$ and C that make the sum term $\bar{A} + B + C = 0$.
- 2- Determine the values of $A, B,$ and C that make the product term $\bar{A}BC = 1$.
- 3- Draw the logic circuit for the Boolean expression $(A + B)(B + C + D)$.
- 4- Implement the expression $AB + BCD + EFGH$ with logic gates.

المحاضرة الثامنة - الزمن: 90 دقيقة 8th week : De Morgan's theorems.

أهداف المحاضرة الثامنة:

يتوقع في نهاية الجلسة أن يكون الطالب قادراً على:

1. Apply the commutative, associative, and distributive laws of addition and multiplication.
2. Apply twelve basic rules of Boolean algebra.

موضوعات المحاضرة الثامنة:

1. Laws of Boolean Algebra
2. Rules of Boolean Algebra

الأساليب والأنشطة والوسائل التعليمية

م	الأساليب والأنشطة التدريسية	الوسائل التدريسية
1	<ul style="list-style-type: none">• نشاط التعارف• محاضرة• مناقشة• سؤال وجواب	<ul style="list-style-type: none">• جهاز حاسوب• جهاز عرض• سبورة• اوراق واقلام

خطة إجراءات تنفيذ المحاضرة الثامنة

الزمن بالدقيقة	الإجراءات	المحاضرة
90 دقيقة	<ul style="list-style-type: none">الترحيب بالطلبةمراجعة سريعة للمادة الدراسية السابقة + اختبارالتعريف بأهداف المحاضرة واهميتهاالقاء المادة العلمية وفتح باب النقاشحل امثلة وتكليف الطلبة بالواجبات	الثامنة

Laws and theorems of Boolean algebra

As in other areas of mathematics, there are certain well-developed rules and laws that must be followed in order to properly apply Boolean algebra. The most important of these are presented in this lecture.

Lecture objectives

At the end of this lecture, the student should be able to:

- 1- Apply the commutative, associative, and distributive laws of addition and multiplication.
- 2- Apply twelve basic rules of Boolean algebra.

Laws of Boolean Algebra

The basic laws of Boolean algebra—the commutative laws for addition and multiplication, the associative laws for addition and multiplication, and the distributive law—are the same as in ordinary algebra. Each of the laws is illustrated with two or three variables, but the number of variables is not limited to this.

Commutative laws

The commutative laws of addition or multiplication for two variables are as follows:

$$A + B = B + A$$

$$AB = BA$$

Associative laws

The commutative laws of addition or multiplication for three variables are as follows:

$$A + (B + C) = (A + B) + C$$

$$A(BC) = (AB)C$$

Distributive law

The distributive law for three variables is as follows:

$$A(B + C) = AB + AC$$

Rules of Boolean Algebra

The following table presents the 12 rules of simplifying and manipulating Boolean expressions.

Basic rules of Boolean algebra.	
1. $A + 0 = A$	7. $A \cdot A = A$
2. $A + 1 = 1$	8. $A \cdot \bar{A} = 0$
3. $A \cdot 0 = 0$	9. $\bar{\bar{A}} = A$
4. $A \cdot 1 = A$	10. $A + AB = A$
5. $A + A = A$	11. $A + \bar{A}B = A + B$
6. $A + \bar{A} = 1$	12. $(A + B)(A + C) = A + BC$

A, B, or C can represent a single variable or a combination of variables

1. $A + 0 = A$



2. $A + 1 = 1$

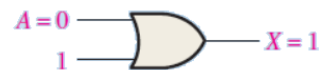

3. $A \cdot 0 = 0$

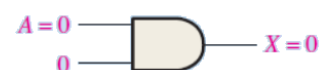

4. $A \cdot 1 = A$

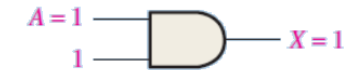

5. $A + A = A$

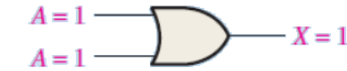
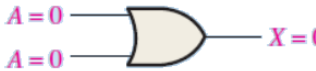

6. $A + \bar{A} = 1$



7. $A \cdot A = A$



8. $A \cdot \bar{A} = 0$



9. $\bar{\bar{A}} = A$

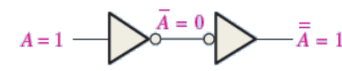
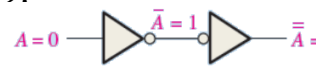

$$10. A + AB = A$$

$$\begin{aligned} A + AB &= A \cdot 1 + AB = A(1 + B) && \text{Factoring (distributive law)} \\ &= A \cdot 1 && \text{Rule 2: } (1 + B) = 1 \\ &= A && \text{Rule 4: } A \cdot 1 = A \end{aligned}$$

$$11. A + \bar{A}B = A + B$$

$$\begin{aligned} A + \bar{A}B &= (A + AB) + \bar{A}B && \text{Rule 10: } A = A + AB \\ &= (AA + AB) + \bar{A}B && \text{Rule 7: } A = AA \\ &= AA + AB + A\bar{A} + \bar{A}B && \text{Rule 8: adding } A\bar{A} = 0 \\ &= (A + \bar{A})(A + B) && \text{Factoring} \\ &= 1 \cdot (A + B) && \text{Rule 6: } A + \bar{A} = 1 \\ &= A + B && \text{Rule 4: drop the 1} \end{aligned}$$

$$12. (A + B)(A + C) = A + BC$$

$$\begin{aligned} (A + B)(A + C) &= AA + AC + AB + BC && \text{Distributive law} \\ &= A + AC + AB + BC && \text{Rule 7: } AA = A \\ &= A(1 + C) + AB + BC && \text{Factoring (distributive law)} \\ &= A \cdot 1 + AB + BC && \text{Rule 2: } 1 + C = 1 \\ &= A(1 + B) + BC && \text{Factoring (distributive law)} \\ &= A \cdot 1 + BC && \text{Rule 2: } 1 + B = 1 \\ &= A + BC && \text{Rule 4: } A \cdot 1 = A \end{aligned}$$

Example: Simplify the following expressions using Boolean algebra rules and laws.

$$1) y = A\bar{B}D + A\bar{B}\bar{D}$$

$$2) z = (\bar{A} + B)(A + B)$$

Solution:

$$1) y = A\bar{B}D + A\bar{B}\bar{D} = A\bar{B}(D + \bar{D}) = A\bar{B} \cdot 1 = A\bar{B}$$

$$2) z = (\bar{A} + B)(A + B) = \bar{A}A + \bar{A}B + BA + BB = 0 + B(\bar{A} + A) + B = 0 + B + B = B$$

Exercise (Lecture 08)

Answer the following:

1- Apply the associative law of addition to the expression:

$$A + (B + C + D).$$

2- Apply the distributive law to the expression:

$$A(B + C + D).$$

3- Simplify the following expression using Boolean algebra rules and laws.

$$y = AB + A(B + C) + B(B + C)$$

4- Simplify the following expression using Boolean algebra rules and laws.

$$y = [A\bar{B}(C + BD) + \bar{A}B]C$$

المحاضرة التاسعة - الزمن: 90 دقيقة

9th week : Laws and theorem of Boolean algebra.

أهداف المحاضرة التاسعة:

يتوقع في نهاية الجلسة أن يكون الطالب قادراً على:

1. State DeMorgan's theorems
2. Relate DeMorgan's theorems to the equivalency of the NAND and negative-OR gates and to the equivalency of the NOR and negative-AND gates.

موضوعات المحاضرة التاسعة:

1. DeMorgan's first theorem
2. DeMorgan's second theorem
3. Applying DeMorgan's theorems

الأساليب والأنشطة والوسائل التعليمية

م	الأساليب والأنشطة التدريسية	الوسائل التدريسية
1	<ul style="list-style-type: none">• نشاط التعارف• محاضرة• مناقشة• سؤال وجواب	<ul style="list-style-type: none">• جهاز حاسوب• جهاز عرض• سبورة• اوراق واقلام

خطة إجراءات تنفيذ المحاضرة التاسعة

الزمن بالدقيقة	الإجراءات	المحاضرة
90 دقيقة	<ul style="list-style-type: none">الترحيب بالطلبةمراجعة سريعة للمادة الدراسية السابقة + اختبارالتعريف بأهداف المحاضرة وأهميتهاالقاء المادة العلمية وفتح باب النقاشحل امثلة وتكليف الطلبة بالواجبات	التاسعة

De Margan's theorems

In practical terms, DeMorgan's theorems provide mathematical verification of the equivalency of the NAND and negative-OR gates and the equivalency of the NOR and negative-AND gates. The DeMorgan's theorems used for simplifying the Boolean expressions.

Lecture objectives

At the end of this lecture, the student should be able to:

- 1- State DeMorgan's theorems
- 2- Relate DeMorgan's theorems to the equivalency of the NAND and negative-OR gates and to the equivalency of the NOR and negative-AND gates.

DeMorgan's first theorem

The complement of a product of variables is equal to the sum of the complements of the variables.

Stated another way,

The complement of two or more ANDed variables is equivalent to the OR of the complements of the individual variables.

The formula for expressing this theorem for two variables is

$$\overline{XY} = \bar{X} + \bar{Y}$$

DeMorgan's second theorem

DeMorgan's second theorem is stated as follows:

The complement of a sum of variables is equal to the product of the complements of the variables.

Stated another way,

The complement of two or more ORed variables is equivalent to the AND of the complements of the individual variables.

The formula for expressing this theorem for two variables is

$$\overline{X + Y} = \bar{X} \cdot \bar{Y}$$

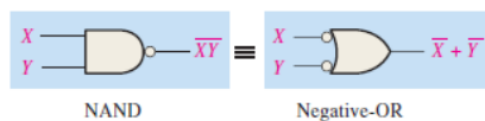

Inputs		Output	
X	Y	\overline{XY}	$\bar{X} + \bar{Y}$
0	0	1	1
0	1	1	1
1	0	1	1
1	1	0	0

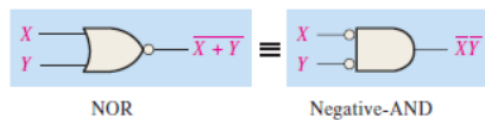

Inputs		Output	
X	Y	$\bar{X} + \bar{Y}$	$\bar{X}\bar{Y}$
0	0	1	1
0	1	0	0
1	0	0	0
1	1	0	0

Example: Apply DeMorgan's theorems to the expressions $\overline{X + Y + Z}$, and \overline{XYZ} .

Solution:

$$\overline{X + Y + Z} = \bar{X} \cdot \bar{Y} \cdot \bar{Z}$$

$$\overline{XYZ} = \bar{X} + \bar{Y} + \bar{Z}$$

Applying DeMorgan's theorems

The following procedure illustrates the application of DeMorgan's theorems and Boolean algebra to the specific expression.

Let's consider the following Boolean expression:

$$\overline{\overline{A + BC} + D(E + \overline{F})}$$

Step 1: Identify the terms to which you can apply DeMorgan's theorems, and think of each term as a single variable. Let $\overline{A + BC} = X$ and $D(E + \overline{F}) = Y$.

Step 2: Since $\overline{X + Y} = \overline{X} \overline{Y}$,

$$\overline{(\overline{A + BC}) + D(E + \overline{F})} = \overline{\overline{A + BC}} \overline{D(E + \overline{F})}$$

Step 3: Use rule 9 ($\overline{\overline{A}} = A$) to cancel the double bars over the left term (this is not part of DeMorgan's theorem).

$$\overline{\overline{\overline{A + BC}}} \overline{D(E + \overline{F})} = (A + BC) \overline{D(E + \overline{F})}$$

Step 4: Apply DeMorgan's theorem to the second term.

$$(A + BC) \overline{D(E + \overline{F})} = (A + BC) (\overline{D} + \overline{E + \overline{F}})$$

Step 5: Use rule 9 ($\overline{\overline{A}} = A$) to cancel the double bars over the $E + \overline{F}$ part of the term.

$$(A + BC) (\overline{D} + \overline{\overline{E + \overline{F}}}) = (A + BC) (\overline{D} + E + \overline{F})$$

Exercise (Lecture 09)

Apply DeMorgan's theorems to each of the following expression:

1- $\overline{(A + B + C)D}$

2- $\overline{ABC + DEF}$

المحاضرة العاشرة - الزمن: 90 دقيقة

10th week : Laws and theorem of Boolean algebra.

أهداف المحاضرة العاشرة:

يتوقع في نهاية الجلسة أن يكون الطالب قادراً على:

1. Apply DeMorgan's theorems to simplify the complex Boolean expressions.

موضوعات المحاضرة العاشرة:

1. Recall DeMorgan's theorems
2. Simplifying Boolean expression using DeMorgan's theorems
3. Circuit implementation based on simplified Boolean expression

الأساليب والأنشطة والوسائل التعليمية

م	الأساليب والأنشطة التدريسية	الوسائل التدريسية
1	<ul style="list-style-type: none">• نشاط التعارف• محاضرة• مناقشة• سؤال وجواب	<ul style="list-style-type: none">• جهاز حاسوب• جهاز عرض• سبورة• اوراق واقلام

خطة إجراءات تنفيذ المحاضرة العاشرة

الزمن بالدقيقة	الإجراءات	المحاضرة
90 دقيقة	<ul style="list-style-type: none">الترحيب بالطلبةمراجعة سريعة للمادة الدراسية السابقة + اختبارالتعريف باهداف المحاضرة واهميتهاالقاء المادة العلمية وفتح باب النقاشحل امثلة وتكليف الطلبة بالواجبات	العاشرة

Boolean expressions simplification using DeMorgan's theorems

This lecture presents the method of simplifying Boolean expressions using DeMorgan's theorems.

Lecture objectives

At the end of this lecture, the student should be able to:

Apply DeMorgan's theorems to simplify the complex Boolean expressions.

Recall DeMorgan's theorems

As explained in the previous lecture, DeMorgan's theorems are as follows:

$$\overline{XY} = \bar{X} + \bar{Y}$$

$$\overline{X + Y} = \bar{X} \cdot \bar{Y}$$

Simplifying Boolean expression using DeMorgan's theorems

Example: Simplify the following Boolean expressions using DeMorgan's theorems.

$$1- Z = \overline{(\bar{A} + C) \cdot (B + \bar{D})}$$

$$2- Z = \overline{(A + BC) \cdot (D + EF)}$$

Solution:

$$1- Z = \overline{(\bar{A} + C) \cdot (B + \bar{D})}$$

$$Z = \overline{(\bar{A} + C) \cdot (B + \bar{D})} = \overline{(\bar{A} + C)} + \overline{(B + \bar{D})} = \bar{\bar{A}} \cdot \bar{C} + \bar{B} \cdot \bar{\bar{D}} = AC + \bar{B}D$$

$$Z = \overline{(A + BC) \cdot (D + EF)} = \overline{(A + BC)} + \overline{(D + EF)} = (\bar{A} \cdot \bar{BC}) + (\bar{D} \cdot \bar{EF}) = (\bar{A} \cdot (\bar{B} + \bar{C})) +$$

$$2- (\bar{D} \cdot (\bar{E} + \bar{F})) = \bar{A}\bar{B} + \bar{A}\bar{C} + \bar{D}\bar{E} + \bar{D}\bar{F}$$

Example: Apply DeMorgan's theorems to each of the following expressions.

$$1- Z = \overline{(A + B + C)D}$$

$$2- Z = \overline{(\bar{A} + \bar{B}) + \bar{C}}$$

$$3- Z = \overline{(\bar{A} + B) + CD}$$

$$4- Z = \overline{ABC + (\bar{D} + E)}$$

Solution:

$$1- Z = \overline{(A + B + C)D}$$

$$Z = \overline{(A + B + C)D} = \overline{(A + B + C)} + \bar{D} = (\bar{A} \cdot \bar{B} \cdot \bar{C}) + \bar{D} = \bar{A}\bar{B}\bar{C} + \bar{D}$$

$$2- Z = \overline{(\bar{A} + \bar{B}) + \bar{C}}$$

$$Z = \overline{(\bar{A} + \bar{B}) + \bar{C}} = \overline{(\bar{A} + \bar{B})} \cdot \bar{\bar{C}} = (A + B) \cdot C = AC + BC$$

$$3- Z = \overline{(\bar{A} + B) + CD} = \overline{(\bar{A} + B)} \cdot \bar{CD} = \bar{\bar{A}} \cdot \bar{B} \cdot (\bar{C} + \bar{D}) = A\bar{B}\bar{C} + A\bar{B}\bar{D}$$

$$4- Z = \overline{ABC + (\bar{D} + E)} = \bar{A} + \bar{B} + \bar{C} + \bar{\bar{D} + E} = \bar{A} + \bar{B} + \bar{C} + D\bar{E}$$

Circuit implementation based on simplified Boolean expression

Example: Implement a circuit having the output expression:

$$Z = \bar{A} + \bar{B} + C$$

Using NAND gate and an inverter.

Solution: The output of the NAND gate is the multiplication of its inputs, therefore, the addition in the Boolean expression must be converted to multiplication which can be accomplished by applying DeMorgan's theorems.

$$Z = \overline{\bar{A} + \bar{B} + C} = \bar{\bar{A}} \cdot \bar{\bar{B}} \cdot \bar{C} = A \cdot B \cdot \bar{C}$$

The result can be implemented using NAND gate with three inputs: A, B, and inverted C.

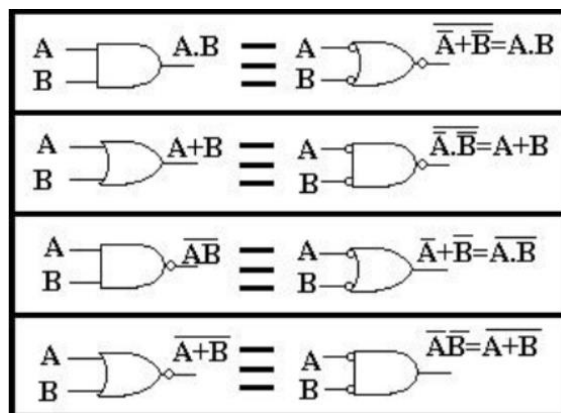
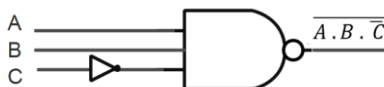

Exercise (Lecture 10)

Answer the following:

A) Apply DeMorgan's theorems to each of the following expressions.

1- $Z = \overline{ABC + DEF}$

2- $Z = \overline{A\bar{B} + \bar{C}D + DEF}$

3- $Z = \overline{(A+B)\bar{C}D + E + \bar{F}}$

B) Check the following sentences and write true or false.

- 1- Variable, complement, and literal are all terms used in Boolean algebra.
- 2- Addition in Boolean algebra is equivalent to the NOR function.
- 3- Multiplication in Boolean algebra is equivalent to the AND function.
- 4- The commutative law, associative law, and distributive law are all laws in Boolean algebra.
- 5- The complement of 0 is 0 itself.
- 6- When a Boolean variable is multiplied by its complement, the result is the variable.
- 7- "The complement of a product of variables is equal to the sum of the complements of each variable" is a statement of DeMorgan's theorem.

المحاضرة الحادية عشر - الزمن: 90 دقيقة 11th week : Arithmetic circuit.

أهداف المحاضرة الحادية عشر:

يتوقع في نهاية الجلسة أن يكون الطالب قادراً على:

1. Determine the Boolean expression for a combination of gates.
2. Evaluate the logic operation of a circuit from the Boolean expression.
3. Construct a truth table.

موضوعات المحاضرة الحادية عشر:

1. Boolean Expression for a Logic Circuit
2. Constructing a Truth Table for a Logic Circuit
3. Circuit implementation based on simplified Boolean expression

الأساليب والأنشطة والوسائل التعليمية

م	الأساليب والأنشطة التدريسية	الوسائل التدريسية
1	<ul style="list-style-type: none">• نشاط التعارف• محاضرة• مناقشة• سؤال وجواب	<ul style="list-style-type: none">• جهاز حاسوب• جهاز عرض• سبورة• اوراق واقلام

خطة إجراءات تنفيذ المحاضرة الحادية عشر

المحاضرة	الإجراءات	الزمن بالدقيقة
الحادية عشر	الترحيب بالطلبة	90 دقيقة
	مراجعة سريعة للمادة الدراسية السابقة + اختبار	
	التعريف بأهداف المحاضرة وأهميتها	
	القاء المادة العلمية وفتح باب النقاش حل امثلة وتكليف الطلبة بالواجبات	

Arithmetic circuit

Boolean algebra provides a concise way to express the operation of a logic circuit formed by a combination of logic gates so that the output can be determined for various combinations of input values.

Lecture objectives

At the end of this lecture, the student should be able to:

- 1- Determine the Boolean expression for a combination of gates.
- 2- Evaluate the logic operation of a circuit from the Boolean expression.
- 3- Construct a truth table.

Boolean Expression for a Logic Circuit

To derive the Boolean expression for a logic circuit, begin at the left-most inputs toward the final output, write the expression for each gate.

Example: The Boolean expression for the logic circuits shown below can be determined using three steps:

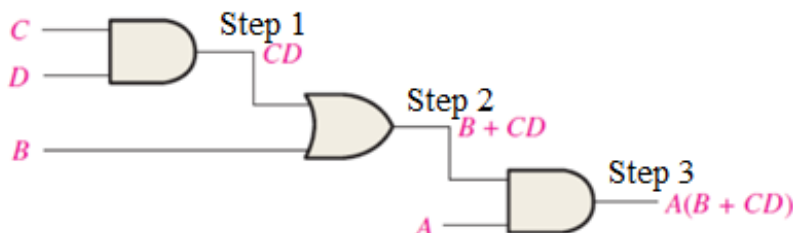

Constructing a Truth Table for a Logic Circuit

The truth table for a logic circuit can be determined from its Boolean expression by taking all the possible values of the input variables. The number of possible combinations of the input variables depends on the number of input variables as follows:

$$\text{Number of combinations} = 2^{\text{no. of variables}}$$

Example: For 4 input variables (A, B, C, and D) there are $2^4 = 16$ possible combinations of values.

Circuit implementation based on simplified Boolean expression

Example: Construct the truth table for the Boolean expression: $X = \bar{A} B$.

Solution: The number of variables is 2 therefore there are 4 possible combinations as shown in table below:

A	B	$X = \bar{A} B$
0	0	0
0	1	1
1	0	0
1	1	0

Example: Construct the truth table for the Boolean expression:

$$X = ABC\bar{C} + A\bar{B}C + \bar{A}BC + ABC.$$

Solution: The number of variables is 3 therefore there are 8 possible combinations as shown in table below:

A	B	C	$X = ABC\bar{C} + A\bar{B}C + \bar{A}BC + ABC$	
0	0	0	0	
0	0	1	0	
0	1	0	0	
0	1	1	1	$\bar{A}BC$
1	0	0	0	
1	0	1	1	$A\bar{B}C$
1	1	0	1	$ABC\bar{C}$
1	1	1	1	ABC

Example: Construct the truth table for the Boolean expression: $X = A(B + CD)$.

Solution: The number of variables is 4 therefore there are 16 possible combinations as shown in table below:

A	B	C	D	$X = A(B + CD)$
0	0	0	0	0
0	0	0	1	0
0	0	1	0	0
0	0	1	1	0
0	1	0	0	0
0	1	0	1	0
0	1	1	0	0
0	1	1	1	0
1	0	0	0	0
1	0	0	1	0
1	0	1	0	0
1	0	1	1	1
1	1	0	0	1
1	1	0	1	1
1	1	1	0	1
1	1	1	1	1

Exercise (Lecture 11)

Construct the truth table for the Boolean expressions:

- 1- $X = A\bar{B} + \bar{A}B$
- 2- $X = A(B + \bar{C}D)$

المحاضرة الثانية عشر - الزمن: 90 دقيقة 12th week : Arithmetic circuit.

أهداف المحاضرة الثانية عشر:

يتوقع في نهاية الجلسة أن يكون الطالب قادراً على:

1. Apply the laws, rules, and theorems of Boolean algebra to simplify general expressions.

موضوعات المحاضرة الثانية عشر:

1. Boolean simplification

الأساليب والأنشطة والوسائل التعليمية

م	الأساليب والأنشطة التدريسية	الوسائل التدريسية
1	<ul style="list-style-type: none">• نشاط التعارف• محاضرة• مناقشة• سؤال وجواب	<ul style="list-style-type: none">• جهاز حاسوب• جهاز عرض• سبورة• اوراق واقلام

خطة إجراءات تنفيذ المحاضرة الثانية عشر

الزمن بالدقيقة	الإجراءات	المحاضرة
90 دقيقة	<ul style="list-style-type: none">الترحيب بالطلبةمراجعة سريعة للمادة الدراسية السابقة + اختبارالتعريف باهداف المحاضرة واهميتهاالقاء المادة العلمية و فتح باب النقاشحل امثلة وتكليف الطلبة بالواجبات	الثانية عشر

Logic Simplification Using Boolean Algebra

A logic expression can be reduced to its simplest form or changed to a more convenient form to implement the expression most efficiently using Boolean algebra. The approach taken in this section is to use the basic laws, rules, and theorems of Boolean algebra to manipulate and simplify an expression.

Lecture objectives

At the end of this lecture, the student should be able to:

Apply the laws, rules, and theorems of Boolean algebra to simplify general expressions.

Boolean simplification.

This lecture presents examples on Boolean simplification and its benefit in designing logic circuits.

Example: Using Boolean algebra techniques, simplify the following expression and design the logic circuit before and after the simplification.

$$X = AB + A(B + C) + B(B + C)$$

Solution:

$$\begin{aligned} X &= AB + A(B + C) + B(B + C) \\ &= AB + AB + AC + BB + BC && \text{[Rule 5 } AB+AB=AB\text{]} \\ &= AB + AC + BB + BC && \text{[Rule 7 } BB=B\text{]} \\ &= AB + AC + B && \text{[Rule 10 } B+BC=B\text{]} \\ &= AB + AC + B && \text{[Rule 10 } AB+B=B\text{]} \\ &= B + AC \end{aligned}$$

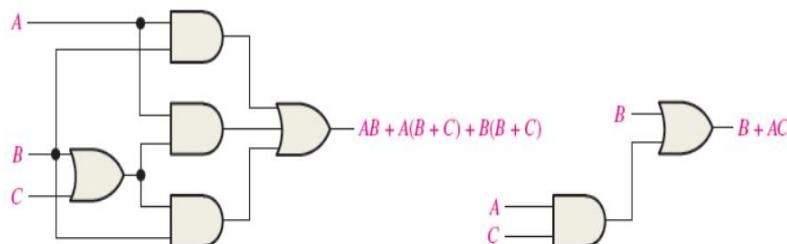

Example: Using Boolean algebra techniques, simplify the following expression and explain the difference between logic circuit before and after the simplification.

$$X = (\bar{A} + B)C + ABC$$

Solution:

$$X = (\bar{A} + B)C + ABC = \bar{A}C + BC + ABC = \bar{A}C + BC(1 + A) = C(\bar{A} + B)$$

Original logic circuit: 2 OR gates, 2 AND gates, 1 inverter; Simplified logic circuit: 1 OR gate, 1 AND gate, 1 inverter

Exercise (Lecture 12)

1- Simplify the following Boolean expression:

$$X = \overline{AB} + \overline{AC} + \bar{A}\bar{B}C$$

2- Using Boolean algebra techniques, simplify the following expression and explain the difference between logic circuit before and after the simplification.

$$X = \bar{A}\bar{B}C(BD + CDE) + \bar{A}\bar{C}$$

المحاضرة الثالثة عشر - الزمن: 90 دقيقة

13th week : Simplifying logic circuits: fundamentals products, sum of products, algebraic simplification.

أهداف المحاضرة الثالثة عشر:

يتوقع في نهاية الجلسة أن يكون الطالب قادراً على:

1. Convert Boolean expression to standard SOP form.
2. Convert Boolean expression to standard POS form.
3. Convert standard SOP to standard POS.

موضوعات المحاضرة الثالثة عشر:

1. SOP form and its domain
2. AND/OR Implementation of an SOP Expression
3. Conversion of a general expression to SOP form
4. Conversion of product terms to standard SOP form
5. POS form
6. OR/AND Implementation of an POS Expression
7. Conversion of sum terms to standard POS form
8. Converting Standard SOP to Standard POS

الأساليب والأنشطة والوسائل التعليمية

الوسائل التدريسية	الأساليب والأنشطة التدريسية	م
<ul style="list-style-type: none">• جهاز حاسوب• جهاز عرض• سبورة• اوراق واقلام	<ul style="list-style-type: none">• نشاط التعارف• محاضرة• مناقشة• سؤال وجواب	1

خطة إجراءات تنفيذ المحاضرة الثالثة عشر

المحاضرة	الإجراءات	الزمن بالدقيقة
الثالثة عشر	الترحيب بالطلبة	90 دقيقة
	مراجعة سريعة للمادة الدراسية السابقة + اختبار	
	التعريف بأهداف المحاضرة وأهميتها	
	القاء المادة العلمية وفتح باب النقاش	
	حل امثلة وتكليف الطلبة بالواجبات	

Standard Forms of Boolean Expressions

All Boolean expressions, regardless of their form, can be converted into either of two standard forms: the sum-of-products (SOP) form or the product-of-sums (POS) form. Standardization makes the evaluation, simplification, and implementation of Boolean expressions much more systematic and easier.

Lecture objectives

At the end of this lecture, the student should be able to:

- 1- Convert Boolean expression to standard SOP form.
- 2- Convert Boolean expression to standard POS form.
- 3- Convert standard SOP to standard POS.

SOP form and its domain

The Boolean expression is called SOP when two or more product terms are summed by Boolean addition.

Example:

$$X = AB + ABC$$

$$X = ABC + CDE + \bar{B}\bar{C}\bar{D}$$

The domain of X is the set of variables in the Boolean expression. For example, the domain of $AB + ABC$ is A, B, and C. The domain of $ABC + CDE + \bar{B}\bar{C}\bar{D}$ is A, B, C, D, and E.

AND/OR Implementation of an SOP Expression

Implementing an SOP expression simply requires ORing the outputs of two or more AND gates.

Example:

$$X = AB + BCD + AC$$

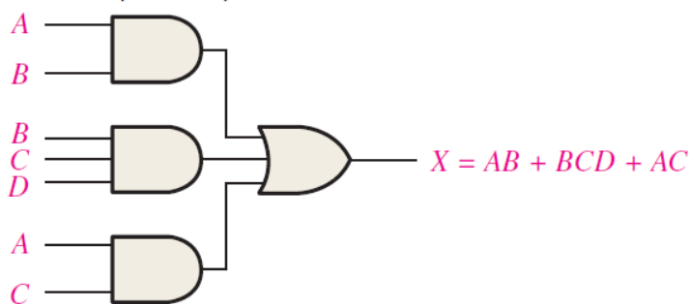

Conversion of a general expression to SOP form

Example: Convert each of the following Boolean expressions to SOP form:

- 1) $X = AB + B(CD + EF)$
- 2) $X = (A + B)(B + C + D)$
- 3) $X = \overline{(A + B)} + C$

Solution:

- 1) $X = AB + B(CD + EF) = AB + BCD + BEF$
- 2) $X = (A + B)(B + C + D) = AB + AC + AD + BB + BC + BD$
- 3) $X = \overline{(A + B)} + C = \overline{(A + B)}. \bar{C} = (A + B). \bar{C} = A\bar{C} + B\bar{C}$

Conversion of product terms to standard SOP form

The conversion to the standard SOP form can be conducted using the following steps:

Step 1: Multiply each nonstandard product term by a term made up of the sum of a missing variable and its complement.

Step 2: Repeat Step 1 until all resulting product terms contain all variables in the domain in either complemented or uncomplemented form.

Example: Convert the following Boolean expressions into standard SOP form:

$$X = A\bar{B}C + \bar{A}\bar{B} + AB\bar{C}D$$

Solution:

$$\begin{aligned} A\bar{B}C &= A\bar{B}C(D + \bar{D}) = A\bar{B}CD + A\bar{B}C\bar{D} \\ \bar{A}\bar{B} &= \bar{A}\bar{B}(C + \bar{C}) = \bar{A}\bar{B}C + \bar{A}\bar{B}\bar{C} = \bar{A}\bar{B}C(D + \bar{D}) + \bar{A}\bar{B}\bar{C}(D + \bar{D}) \\ &= \bar{A}\bar{B}CD + \bar{A}\bar{B}C\bar{D} + \bar{A}\bar{B}\bar{C}D + \bar{A}\bar{B}\bar{C}\bar{D} \\ X &= A\bar{B}CD + A\bar{B}C\bar{D} + \bar{A}\bar{B}CD + \bar{A}\bar{B}C\bar{D} + \bar{A}\bar{B}\bar{C}D + \bar{A}\bar{B}\bar{C}\bar{D} + AB\bar{C}D \end{aligned}$$

POS form

The Boolean expression is called POS when two or more sum terms are multiplied.

Example:

$$\begin{aligned} X &= (\bar{A}B)(A + \bar{B} + C) \\ X &= (A + B + C)(C + D + E)(\bar{B} + C + \bar{D}) \end{aligned}$$

OR/AND Implementation of an POS Expression

Implementing an POS expression simply requires ANDing the outputs of two or more OR gates.

Example:

$$X = (A + B)(B + C + D)(A + C)$$

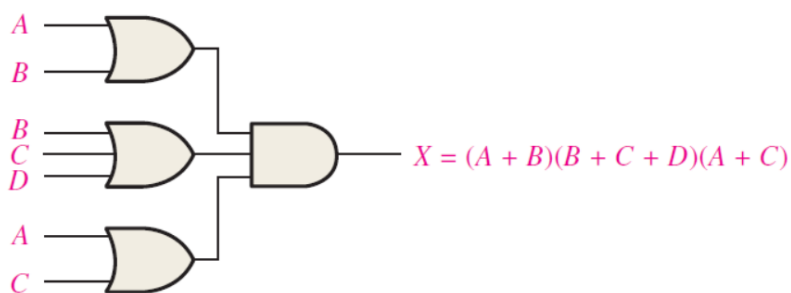

Conversion of sum terms to standard POS form

The conversion to the standard POS form can be conducted using the following steps:

Step 1: Add to each nonstandard product term a term made up of the product of the missing variable and its complement. This results in two sum terms.

Step 2: Apply the Boolean algebra laws and rules.

Step 3: Repeat step 1 until all resulting sum terms contain all variables in the domain in either complemented or uncomplemented form.

Example: Convert the following Boolean expressions into standard POS form:

$$X = (A + \bar{B} + C)(\bar{B} + C + \bar{D})(A + \bar{B} + \bar{C} + D)$$

Solution:

$$A + \bar{B} + C + D\bar{D} = (A + \bar{B} + C + D)(A + \bar{B} + C + \bar{D})$$

$$\bar{B} + C + \bar{D} + A\bar{A} = (A + \bar{B} + C + \bar{D})(\bar{A} + \bar{B} + C + \bar{D})$$

$$X = (A + \bar{B} + C + D)(A + \bar{B} + C + \bar{D})(A + \bar{B} + C + \bar{D})(\bar{A} + \bar{B} + C + \bar{D})(A + \bar{B} + \bar{C} + D)$$

Converting Standard SOP to Standard POS

The binary values of the product terms in a given standard SOP expression are not present in the equivalent standard POS expression and vice versa. Therefore, to convert from standard SOP to standard POS, the following steps are taken:

Step 1: Evaluate each product term in the SOP expression. That is, determine the binary numbers that represent the product terms.

Step 2: Determine all of the binary numbers not included in the evaluation in Step 1.

Step 3: Write the equivalent sum term for each binary number from Step 2 and express in POS form.

Example: Convert the following SOP expression to an equivalent POS expression:

$$X = \bar{A}\bar{B}\bar{C} + \bar{A}B\bar{C} + \bar{A}BC + A\bar{B}C + ABC$$

Solution:

The evaluation of the expression is as follows:

$$000+010+011+101+111$$

The numbers that didn't appear are: 001, 100, 110 therefore the expression in POS form (where each sum term must equal to 0) is as follows:

$$X = (A + B + \bar{C})(\bar{A} + B + C)(\bar{A} + \bar{B} + C)$$

Exercise (Lecture 13)

1- Convert the following Boolean expressions into standard SOP form:

$$X = W\bar{X}Y + \bar{X}Y\bar{Z} + WX\bar{Y}$$

2- Convert the following Boolean expressions into standard POS form:

$$X = (A + \bar{B})(B + C)$$

المحاضرة الرابعة عشر - الزمن: 90 دقيقة

14th week : Simplifying logic circuits: fundamentals products, sum of products, algebraic simplification.

أهداف المحاضرة الرابعة عشر:

يتوقع في نهاية الجلسة أن يكون الطالب قادراً على:

1. Convert a standard SOP expression into truth table format.
2. Convert a standard POS expression into truth table format.
3. Derive a standard expression from a truth table.

موضوعات المحاضرة الرابعة عشر:

1. Converting SOP expressions to truth table
2. Converting POS expressions to truth table
3. Determining Standard Expressions from a Truth Table

الأساليب والأنشطة والوسائل التعليمية

م	الأساليب والأنشطة التدريسية	الوسائل التدريسية
1	<ul style="list-style-type: none">• نشاط التعارف• محاضرة• مناقشة• سؤال وجواب	<ul style="list-style-type: none">• جهاز حاسوب• جهاز عرض• سبورة• اوراق واقلام

خطة إجراءات تنفيذ المحاضرة الرابعة عشر

الزمن بالدقيقة	الإجراءات	المحاضرة
90 دقيقة	<ul style="list-style-type: none">الترحيب بالطلبةمراجعة سريعة للمادة الدراسية السابقة + اختبارالتعريف بأهداف المحاضرة وأهميتهاالقاء المادة العلمية وفتح باب النقاشحل امثلة وتكليف الطلبة بالواجبات	الرابعة عشر

Boolean expressions and Truth Tables

Standard Boolean expressions can be converted into truth table format using binary values for each term in the expression. The truth table is a common way of presenting, in a concise format, the logical operation of a circuit. Also, standard SOP or POS expressions can be determined from a truth table.

Lecture objectives

At the end of this lecture, the student should be able to:

- 1- Convert a standard SOP expression into truth table format.
- 2- Convert a standard POS expression into truth table format.
- 3- Derive a standard expression from a truth table.

Converting SOP expressions to truth table

Example: Develop a truth table for the standard SOP expression:

$$X = \bar{A}\bar{B}C + A\bar{B}\bar{C} + ABC$$

Solution: The number of variables in the Boolean expression is 3 therefore the number of variables combinations is 8.

A	B	C	X	Product term
0	0	0	0	
0	0	1	1	$\bar{A}\bar{B}C$
0	1	0	0	
0	1	1	0	
1	0	0	1	$A\bar{B}\bar{C}$
1	0	1	0	
1	1	0	0	
1	1	1	1	ABC

Converting POS expressions to truth table

Example: Develop a truth table for the standard POS expression:

$$X = (A + B + C)(A + \bar{B} + C)(A + \bar{B} + \bar{C})(\bar{A} + B + \bar{C})(\bar{A} + \bar{B} + C)$$

Solution: The number of variables in the Boolean expression is 3 therefore the number of variables combinations is 8.

A	B	C	X	Sum term
0	0	0	0	$A + B + C$
0	0	1	1	
0	1	0	0	$A + \bar{B} + C$
0	1	1	0	$A + \bar{B} + \bar{C}$
1	0	0	1	
1	0	1	0	$\bar{A} + B + \bar{C}$
1	1	0	0	
1	1	1	1	$\bar{A} + \bar{B} + C$

Determining Standard Expressions from a Truth Table

To determine the standard SOP expression represented by a truth table, list the binary values of the input variables for which the output is 1. Convert each binary value to the corresponding product term by replacing each 1 with the corresponding variable and each 0 with the corresponding variable complement.

To determine the standard POS expression represented by a truth table, list the binary values for which the output is 0. Convert each binary value to the corresponding sum term by replacing each 1 with the corresponding variable complement and each 0 with the corresponding variable.

Example: Determine the SOP and POS expressions for the following truth table.

Inputs			Output
A	B	C	X
0	0	0	0
0	0	1	0
0	1	0	0
0	1	1	1
1	0	0	1
1	0	1	0
1	1	0	1
1	1	1	1

Solution:

SOP expression:

$$X = \bar{A}BC + A\bar{B}\bar{C} + AB\bar{C} + ABC$$

POS expression:

$$X = (A + B + C). (A + B + \bar{C}). (A + \bar{B} + C). (\bar{A} + B + \bar{C})$$

Example: A four logic-signal A, B, C, D are being used to represent a 4-bit binary number with A as the LSB and D as the MSB. The binary inputs are fed to a logic circuit that produces a logic 1 (HIGH) output only when the binary number is greater than $0110_2 = 6_{10}$. Write the output expression in standard SOP and POS forms.

A	B	C	D	X	Product terms	Sum terms
0	0	0	0	0		$A + B + C + D$
0	0	0	1	0		$A + B + C + \bar{D}$
0	0	1	0	0		$A + B + \bar{C} + D$
0	0	1	1	0		$A + B + \bar{C} + \bar{D}$
0	1	0	0	0		$A + \bar{B} + C + D$
0	1	0	1	0		$A + \bar{B} + C + \bar{D}$
0	1	1	0	0		$A + \bar{B} + \bar{C} + D$
0	1	1	1	1	$\bar{A}BCD$	
1	0	0	0	1	$A\bar{B}\bar{C}\bar{D}$	
1	0	0	1	1	$A\bar{B}\bar{C}D$	
1	0	1	0	1	$A\bar{B}C\bar{D}$	
1	0	1	1	1	$A\bar{B}CD$	
1	1	0	0	1	$AB\bar{C}\bar{D}$	
1	1	0	1	1	$AB\bar{C}D$	
1	1	1	0	1	$ABC\bar{D}$	
1	1	1	1	1	$ABCD$	

SOP expression:

$$X = \bar{A}BCD + A\bar{B}\bar{C}\bar{D} + A\bar{B}\bar{C}D + A\bar{B}C\bar{D} + A\bar{B}CD + AB\bar{C}\bar{D} + AB\bar{C}D + ABC\bar{D} + ABCD$$

POS expression:

$$X = (A + B + C + D)(A + B + C + \bar{D})(A + B + \bar{C} + D)(A + B + \bar{C} + \bar{D})(A + \bar{B} + C + D)(A + \bar{B} + C + \bar{D})(A + \bar{B} + \bar{C} + D)$$

Exercise (Lecture 14)

1- Develop a truth table for the standard SOP expression:

$$X = \bar{A}BC + A\bar{B}C + ABC$$

2- Develop a truth table for the standard POS expression:

$$X = (A + \bar{B} + C)(A + \bar{B} + \bar{C})(\bar{A} + \bar{B} + C)$$

3- Determine the SOP and POS expressions for the following truth table.

A	B	X
0	0	0
0	1	1
1	0	1
1	1	0

المحاضرة الخامسة عشر - الزمن: 90 دقيقة

15th week : Simplifying logic circuits: fundamentals products, sum of products, algebraic simplification.

أهداف المحاضرة الخامسة عشر:

يتوقع في نهاية الجلسة أن يكون الطالب قادراً على:

1. Solve different problems on the previously studied subjects.
2. Evaluate the weakness in his/her information in order to focus on overcome the weakness.

موضوعات المحاضرة الخامسة عشر:

1. Lecture objectives

الأساليب والأنشطة والوسائل التعليمية

م	الأساليب والأنشطة التدريسية	الوسائل التدريسية
1	<ul style="list-style-type: none">• نشاط التعارف• محاضرة• مناقشة• سؤال وجواب	<ul style="list-style-type: none">• جهاز حاسوب• جهاز عرض• سبورة• اوراق واقلام

خطة إجراءات تنفيذ المحاضرة الخامسة عشر

الزمن بالدقيقة	الإجراءات	المحاضرة
90 دقيقة	<ul style="list-style-type: none">الترحيب بالطلبةمراجعة سريعة للمادة الدراسية السابقة + اختبارالتعريف بأهداف المحاضرة وأهميتهاالقاء المادة العلمية وفتح باب النقاشحل امثلة وتكليف الطلبة بالواجبات	الخامسة عشر



Semester I - Tutorial

This lecture is the final lecture in semester I therefore it presents some examples on the subjects that have been studied in the previous lectures.

Lecture objectives

At the end of this lecture, the student should be able to:

- 1- Solve different problems on the previously studied subjects.
- 2- Evaluate the weakness in his/her information in order to focus on overcome the weakness.

1- What weight does the digit 7 have in each of the following numbers?

1370	6725	7051	58.72
------	------	------	-------

Answer:

10	100	1000	0.1
----	-----	------	-----

2- Express each of the following decimal numbers as a sum of the products obtained by multiplying each digit by its appropriate weight:

(a) 51	(b) 137	(c) 1492	(d) 106.58
--------	---------	----------	------------

Answer:

$$(a) 51 = 5 \times 10 + 1 \times 1$$

$$(b) 137 = 1 \times 100 + 3 \times 10 + 7 \times 1$$

$$(c) 1492 = 1 \times 1000 + 4 \times 100 + 9 \times 10 + 2 \times 1$$

$$(d) 106.58 = 1 \times 100 + 0 \times 10 + 6 \times 1 + 5 \times 0.1 + 8 \times 0.01$$

3- Convert the binary number 1101101 to decimal.

Answer:

$$1 \times 2^6 + 1 \times 2^5 + 0 \times 2^4 + 1 \times 2^3 + 1 \times 2^2 + 0 \times 2^1 + 1 \times 2^0$$
$$= 64 + 32 + 8 + 4 + 1 = 109$$

4- Convert the fractional binary number 0.1011 to decimal.

Answer:

$$1 \times 2^{-1} + 0 \times 2^{-2} + 1 \times 2^{-3} + 1 \times 2^{-4} = 0.5 + 0.125 + 0.0625 = 0.6875$$

1- Convert the following decimal numbers to binary:

(a) 12 (b) 82

Answer: (a) 1100 (b) 1010010

Division by 2	Quotient	Remainder
$12 \div 2$	6	0 (LSB)
$6 \div 2$	3	0
$3 \div 2$	1	1
$1 \div 2$	0	1(MSB)
Division by 2	Quotient	Remainder
$82 \div 2$	41	0 (LSB)
$41 \div 2$	20	1
$20 \div 2$	10	0
$10 \div 2$	5	0
$5 \div 2$	2	1
$2 \div 2$	1	0
$1 \div 2$	0	1(MSB)

2- Convert the following binary numbers to hexadecimal: (a) 1100101001010111

(b) 111111000101101001

Answer: (a) (CA57)₁₆ (b) (3F169)₁₆

1- Convert the following decimal numbers to BCD:

- (a) 35 (b) 98 (c) 170

Answer:

(a) $35 = 0011\ 0101$ (in BCD)

(b) $98 = 1001\ 1000$ (in BCD)

(c) $170 = 0001\ 0111\ 0000$ (in BCD)

2- Convert the following BCD to decimal:

- (a) 10000110 (b) 001101010001

Answer:

(a) $1000\ 0110 = 86$

(b) $0011\ 0101\ 0001 = 351$

3- Convert the following binary numbers to Gray code:

- (a) 1100 (b) 1010

Answer: (a) $1100_2 = 1010$ Gray (b) $1010_2 = 1010$ Gray

4- Convert the following Gray codes to binary:

- (a) 1000 (b) 11101

Answer: (a) 1000 Gray = 1111_2

(b) 11101 Gray = 10110_2



نهاية الحقبة التعليمية

Digital Techniques

الفصل الدراسي الأول