



Measurements & Medical Transducers

DC Measuring Instruments

2nd Stage

Lecturer: Dr. Suhail Najm Abdullah

Lecture Four

DC Measuring Instruments

4.1 Analog Ammeters and Voltmeters

- Analog ammeters and voltmeters are classed together as there are no fundamental differences in their operating principles.
- The action of all ammeters and voltmeters depends upon a deflecting torque *إنحراف عزم الدوران* produced by an electric current.
- In an ammeter, this torque is produced by a current to be measured or by a definite fraction of it. In a voltmeter this torque is produced by a current which is proportional to the voltage to be measured.
- The essential requirements of a measuring instrument are:
 - ▶ Its introduction into the circuit, where measurements are needed, does not alter the circuit conditions.
 - ▶ The power consumed by the instrument for their operation is small.

- There are multiple types of analog instruments, such as:
 1. Permanent Magnet Moving Coil. (DC)
 2. Moving Iron. (AC/DC)
 3. Induction. (AC)
 4. Dynamometer. (AC/DC)
 5. Thermocouple. (AC/DC)
- Of these types, the permanent magnet moving coil (**PMMC**) type can be used **for DC measurements only**, while the **induction type for AC** measurements only.
- The other types of analog instruments can be used with either DC or AC measurements.

4.2 Permanent Magnet Moving Coil (PMMC) Instruments

- In PMMC instrument, a coil of fine wire is suspended in a magnetic field produced by permanent magnet. According to the fundamental law of electromagnetic force, the coil will rotate in the magnetic field when it carries an electric current by electromagnetic torque effect. تأثير عزم الدوران الكهرومغناطيسي.
- A pointer مؤشر which attached the movable coil will deflect ينحرف according to the amount of current to be measured which applied to the coil. The torque is counterbalance موازن by the mechanical torque of control springs attached to the **movable coil** also.
- When the torques are balanced, the moving coil will stop and its angular deflection represent the amount of electrical current to be measured against a fixed reference, called a scale.

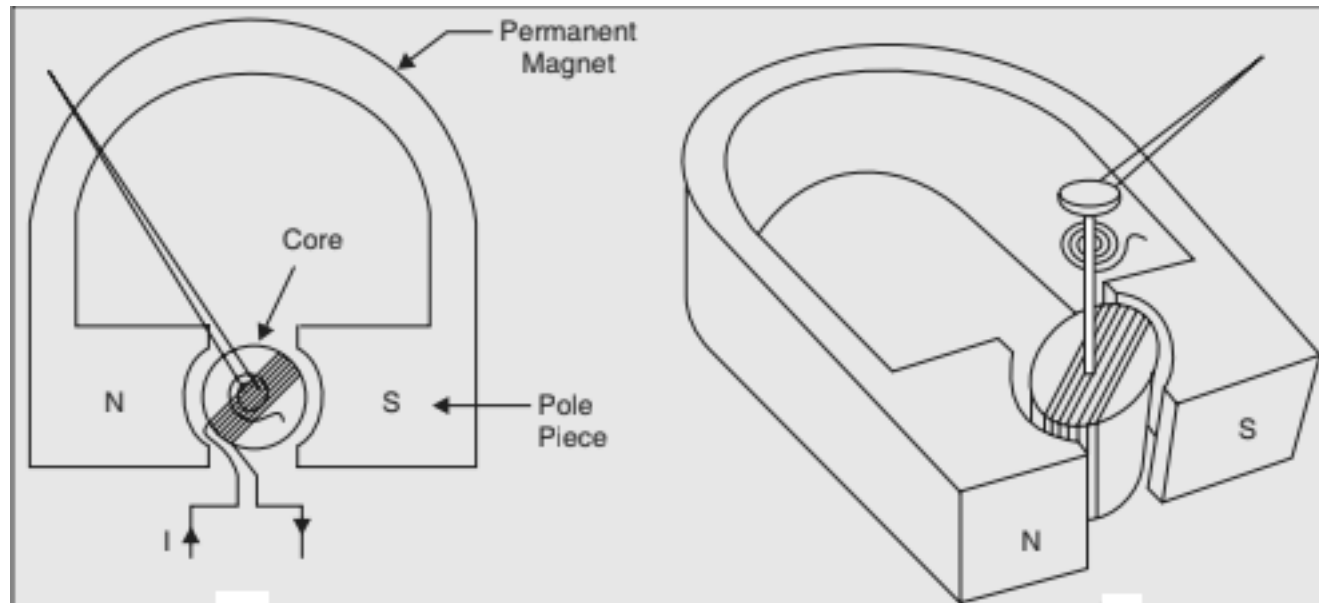

(a)



(b)

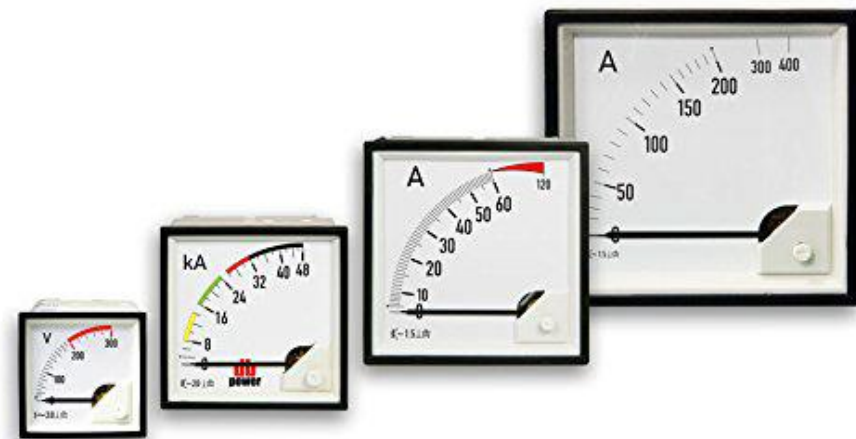

(c)

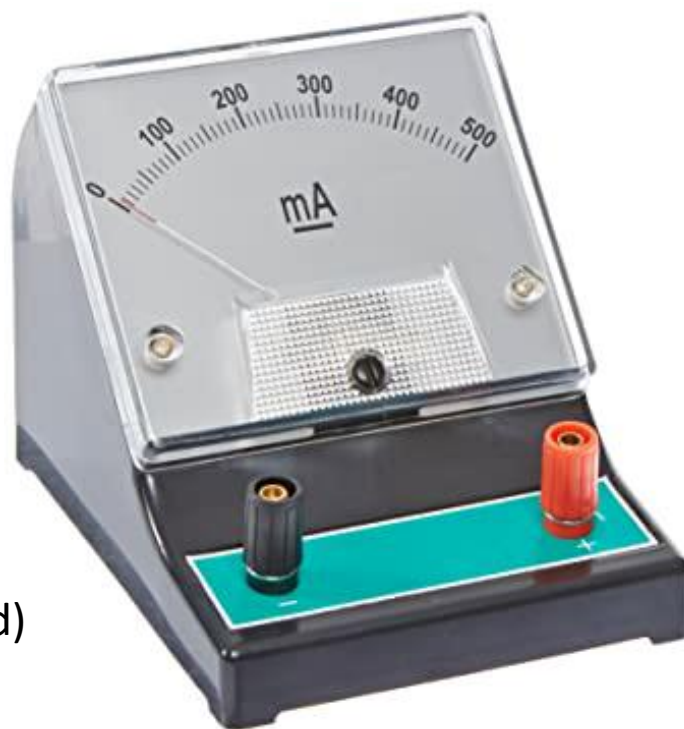

(d)

4.3 PMMC DC Ammeters

- An Ammeter is always connected in series with a circuit branch and measures the current flowing in it.
- An ideal ammeter would be capable of performing the measurement without changing or distributing the current in the branch but real ammeters would possess some internal resistance.

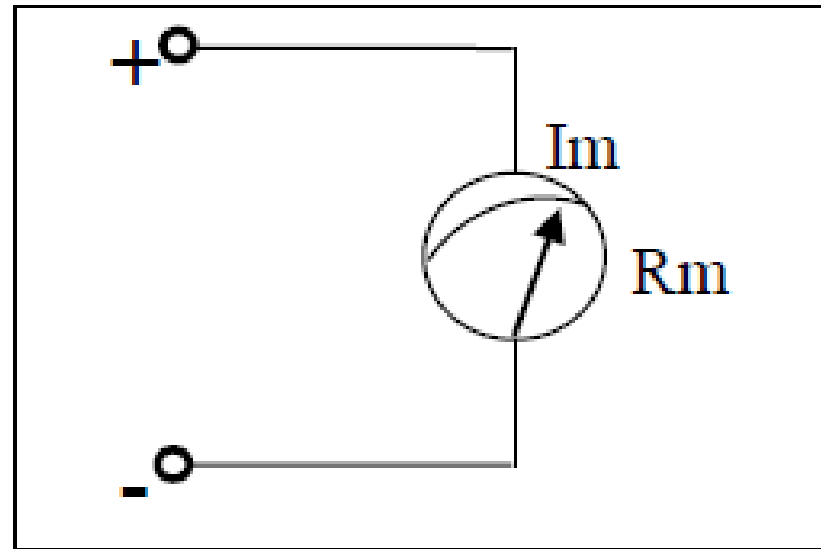

(e)

4.3.1 Extension of DC Ammeter Range

- Since the coil winding in PMMC ammeter is small and light, they can carry only small currents ($1\mu\text{A} - 1\text{mA}$).
- Measurement of large current requires a shunt (parallel) external resistor to connect with the meter movement, so only a fraction of the total current will pass through the meter. We have:

- ▶ R_m : internal resistance of ammeter.
- ▶ I_m : full-scale deflection current.
- ▶ R_{sh} : shunt resistance.
- ▶ I_{sh} : shunt current.
- ▶ I : current to be measured.

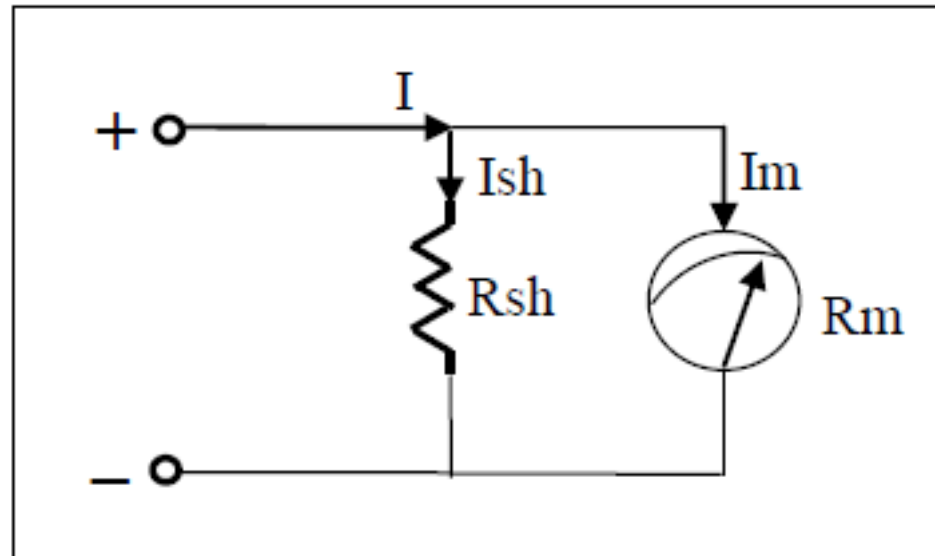

(f)

- Since the two resistors are in parallel, then the voltage across them is equal. So, we can write:

$$\begin{aligned} I_{sh}R_{sh} &= I_mR_m \\ R_{sh} &= I_mR_m/I_{sh} \end{aligned} \quad (1)$$

we also can write:

$$I_{sh} = I - I_m \quad (2)$$

by substituting (2) into (1), we get:

$$R_{sh} = I_mR_m/(I - I_m) \quad (3)$$

Example 1: A (1 mA) ammeter with an internal resistance of 100 Ω is to be converted into a 0-100 mA ammeter. Then, the required shunt resistance is;

$$R_{sh} = 100m * \frac{100}{100m - 1m} = 1.01\Omega$$

3.3.2 Extension of DC Ammeter multi-range

- The range of DC ammeters can be further extended to produce a multi-range instrument. That could be done using either the direct or indirect method.

1) Direct Method:

The current range of a DC ammeter can be further extended by a number of shunts selected by a range switch, as shown below. In this case, we can write;

$$R_{sh1} = I_m R_m / (I_{range1} - I_m)$$

$$R_{sh2} = I_m R_m / (I_{range2} - I_m)$$

$$R_{sh3} = I_m R_m / (I_{range3} - I_m)$$

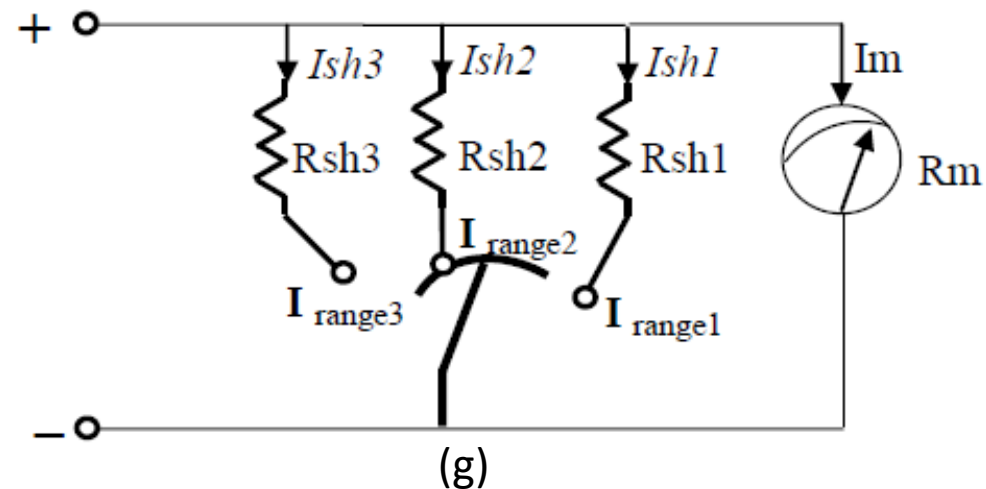

Example 3

We will design a multirange ammeter by using direct method to give the following ranges: 10mA, 100mA, 1A, 10A, and 100A. The ammeter has an internal resistance of 10Ω and full scale current of 1mA . We can write;

$$R_{sh1} = 10^{-3} * 10 / (10\text{m} - 1\text{m}) = 1.11\Omega$$

$$R_{sh2} = 10^{-3} * 10 / (100\text{m} - 1\text{m}) = 0.101\Omega$$

$$R_{sh3} = 10^{-3} * 10 / (1 - 1\text{m}) = 0.0101\Omega$$

$$R_{sh4} = 10^{-3} * 10 / (10 - 1\text{m}) = 0.0011\Omega$$

$$R_{sh5} = 10^{-3} * 10 / (100 - 1\text{m}) = 0.00011\Omega$$

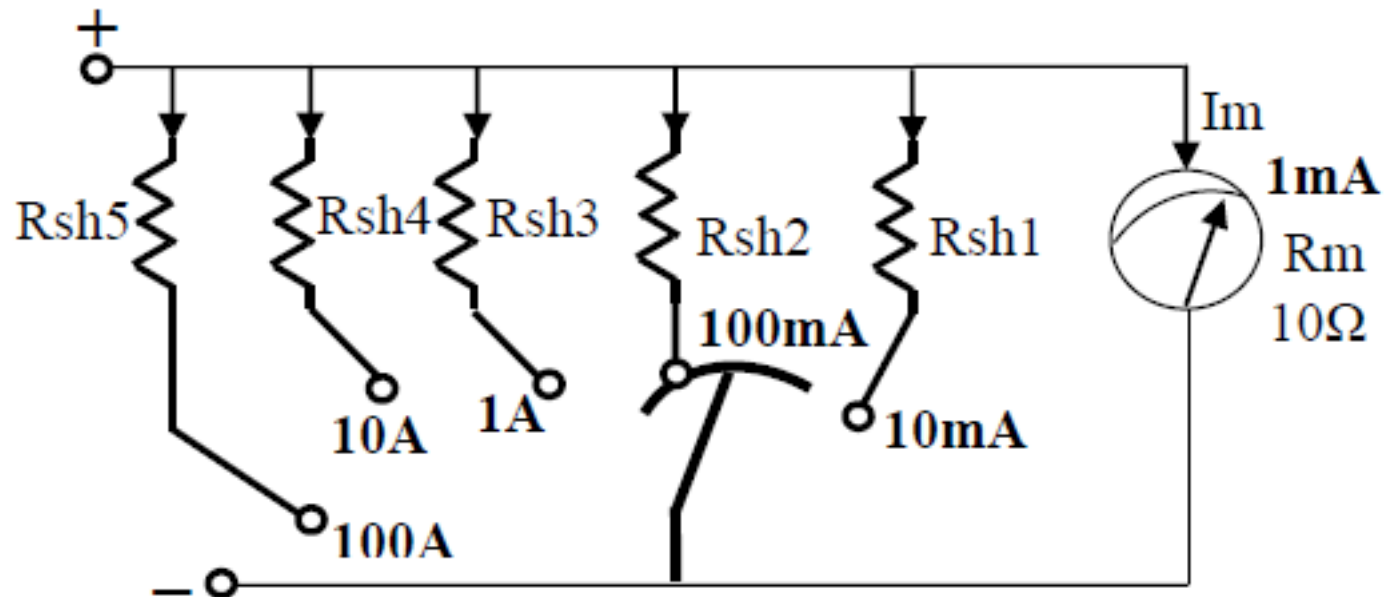

2) Indirect Method (Ayrton):

$$\frac{I_{r*}}{I_m} = \frac{R_m + R}{R_{eq}}$$

where

▶ $R = R_a + R_b + R_c$.

▶ R_{eq} = resistors parallel with the ammeter.

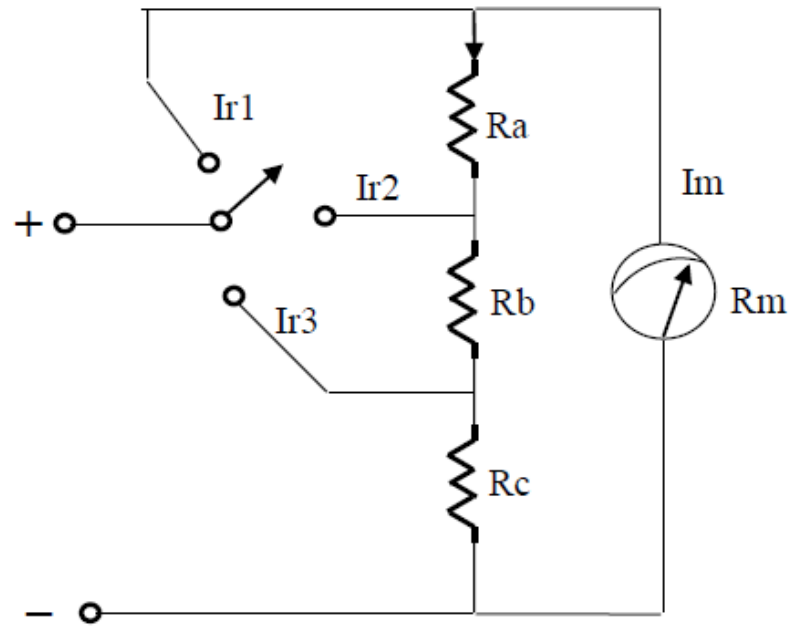

Example 4

We will design a multi-range ammeter by indirect method to provide the ranges: 1A, 5A, and 10A. The ammeter has an internal resistance of 50Ω and full scale current of 1mA .

Sol:

➤ For 1A range: ($R_{eq} = R$):

$$\frac{I_{r1}}{I_m} = \frac{R_m + R}{R_{eq}}$$
$$\frac{1}{1\text{m}} = \frac{50 + R}{R}$$
$$\Rightarrow R = 0.05005\Omega$$

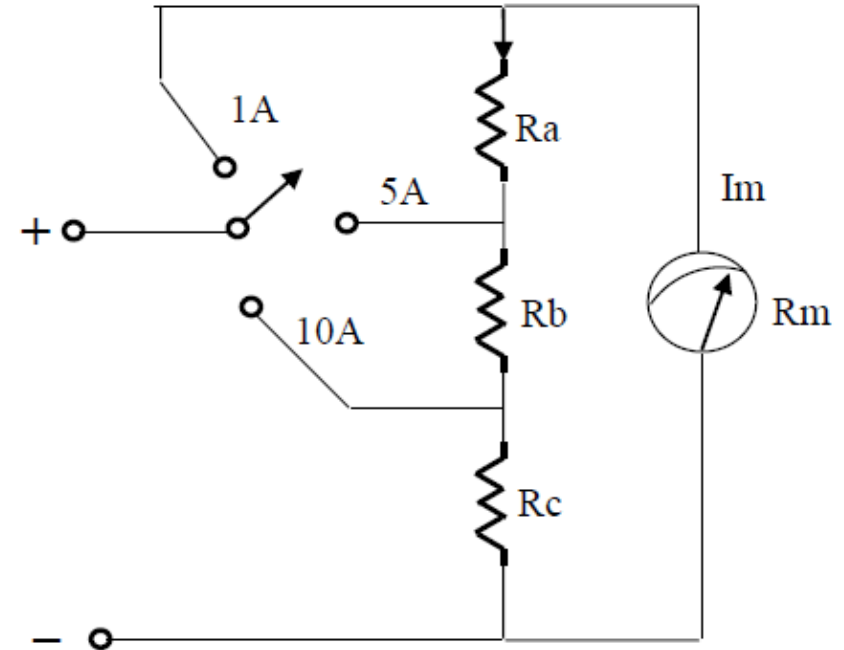

- For 5A range: ($R_{eq} = R_b + R_c$)

$$\frac{I_{r2}}{I_m} = \frac{R_m + R}{R_b + R_c}$$
$$\frac{5}{1m} = \frac{50 + 0.05005}{R_b + R_c}$$

$$\Rightarrow R_b + R_c = 0.01001\Omega$$

$$R_a = R - (R_b + R_c) = 0.04004\Omega$$

- For 10A range: ($R_{eq} = R_c$)

$$\frac{I_{r3}}{I_m} = \frac{R_m + R}{R_c}$$
$$\frac{10}{1m} = \frac{50 + 0.05005}{R_c}$$

$$\Rightarrow R_c = 5.005 \times 10^{-3} \Omega$$

$$R_b = R - (R_a + R_c) = 5.005 \times 10^{-3} \Omega$$

4.4 PMMC DC Voltmeters

- A voltmeter is always connect in parallel with the element being measured, and measures the voltage between the points across which it is connected.
- Most DC voltmeter use a series resistor as shown below. The series resistance should be much larger than R_m .

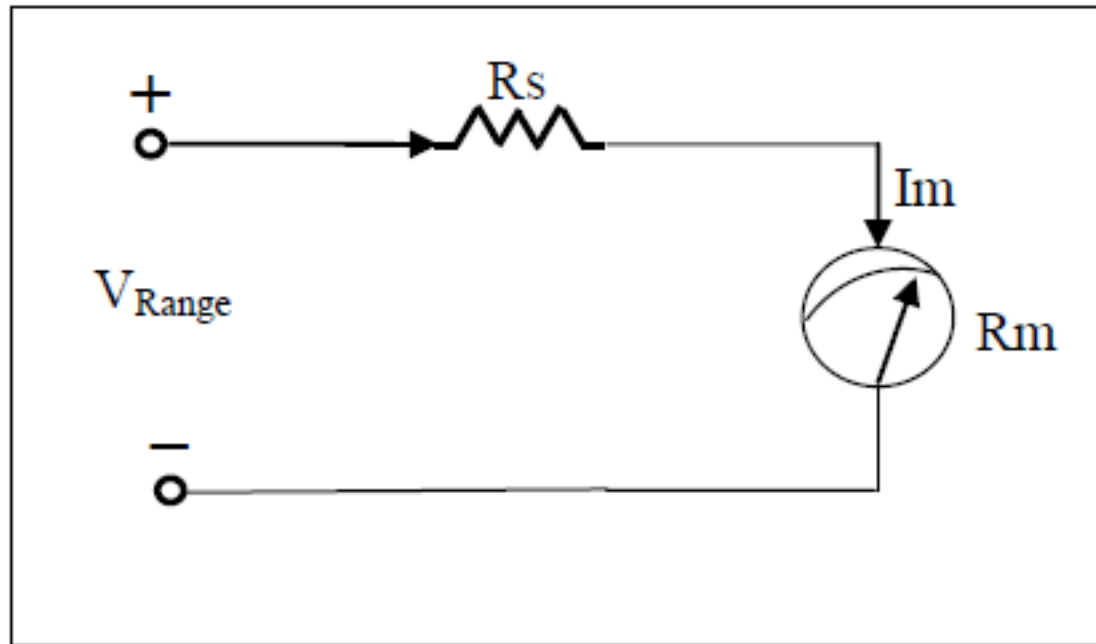

(k)

- So in order to extend the PMMC voltmeter scale and to measure higher voltage values, we need to place a resistor (R_s) in series with the internal resistance (R_m), as shown in figure below.
- From the circuit shown below, we can write;

$$V - I_m R_s - I_m R_m = 0$$
$$\Rightarrow R_s = \frac{V - I_m R_m}{I_m}$$

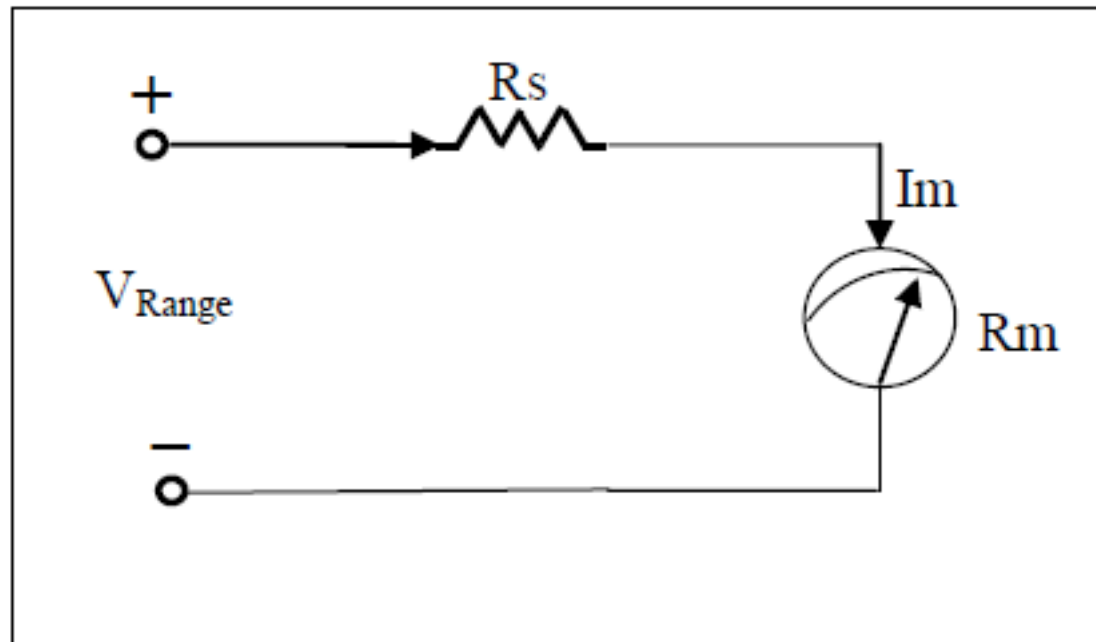

Example 5:

An ammeter with full-scale current (I_m) equals ($100\mu\text{A}$) and ($R_m = 500\Omega$). We need to convert it to a 1V voltmeter. Using Ohm's law, we can write.

Sol:

$$\begin{aligned} V &= 100 * 10^{-6} * 500 \\ &= 50 * 10^{-3} V \end{aligned}$$

- The original range is low. So, we need to determine R_s to increase the voltmeter range to 1V.

$$R_s = \frac{1 - 100 * 10^{-6} * 500}{100 * 10^{-6}} = 9.5k\Omega$$

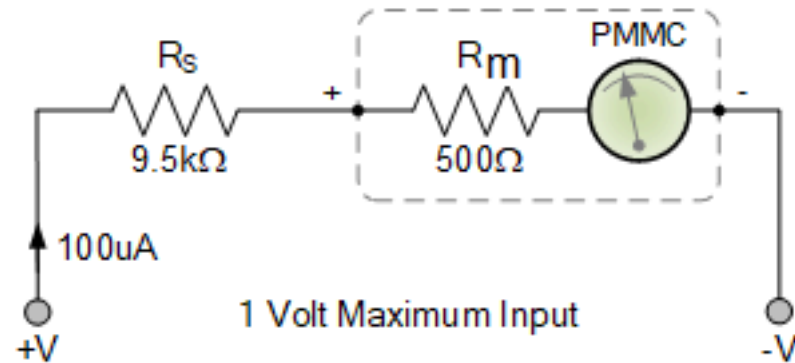

4.4.1 Extension of DC Voltmeter multi-Range

- Ranges of a DC voltmeter can be further extended by adding a number of series resistors to the voltmeter. Each resistor is selected for a certain range. To do this, we can use the "**Direct Method**" or "**Indirect Method**".

1) Direct Method:

In this method, more than one R_s are connected. Each one of the resistors can be calculated as follows

$$R_{s1} = \frac{V_1 - I_m R_m}{I_m}$$

$$R_{s2} = \frac{V_2 - I_m R_m}{I_m}$$

$$R_{s3} = \frac{V_3 - I_m R_m}{I_m}$$

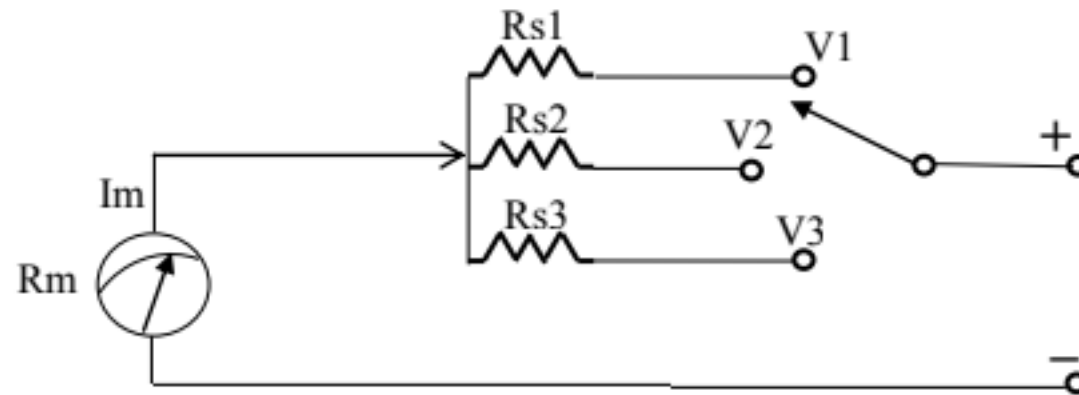

Example 6:

The PMMC voltmeter has a range of 50mV. We extended its range by adding five different resistors to get the ranges (10V, 50V, 100V, 250V, and 500V). Calculate R_{s4} for the range 250V.

Sol:

$$R_{s4} = (250 - 100 * 10^{-6} * 500) / (100 * 10^{-6}) = 2.4995 M\Omega$$

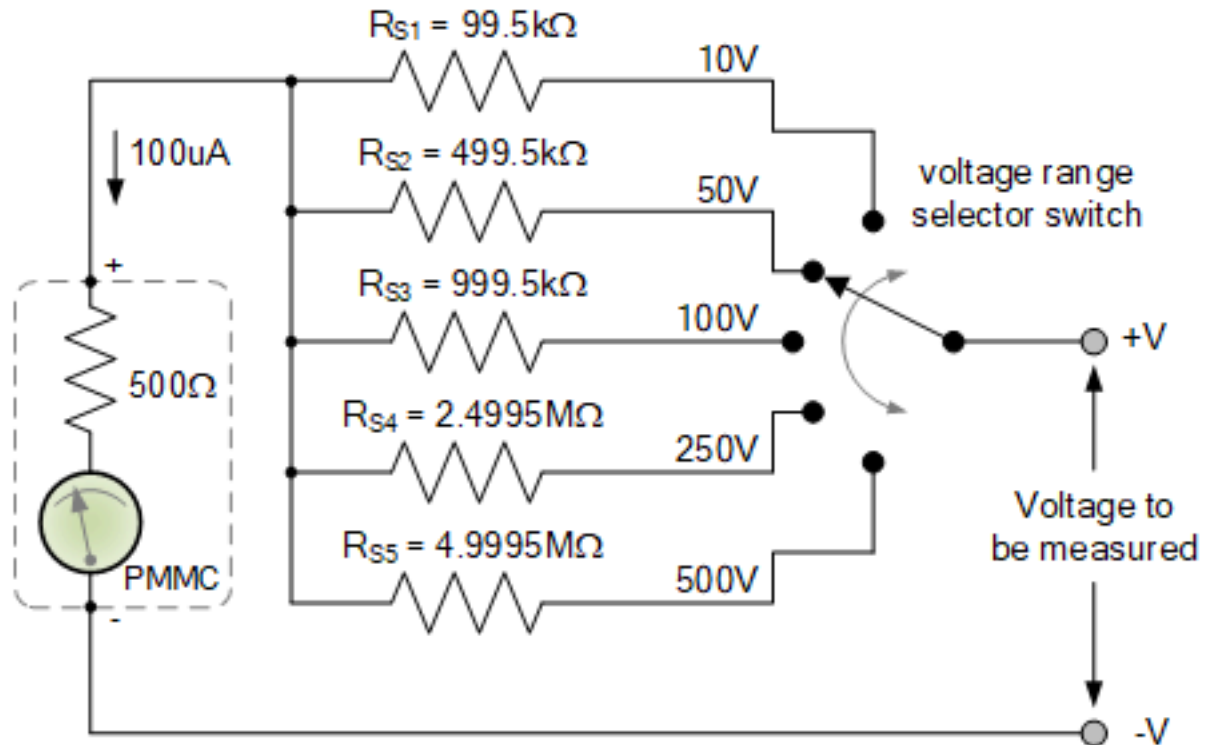

2) Indirect Method:

Using this method, multiple resistors are connected in series with each other and the PMMC voltmeter, as shown below.

- R_{s1} can be calculated the same as we did in the Direct Method as follows;

$$R_{s1} = \frac{V_1 - R_m I_m}{I_m} \quad (1)$$

- R_{s2} can be calculated as follows;

$$V_2 - R_{s1} I_m - R_{s2} I_m - R_m I_m = 0 \quad (2)$$

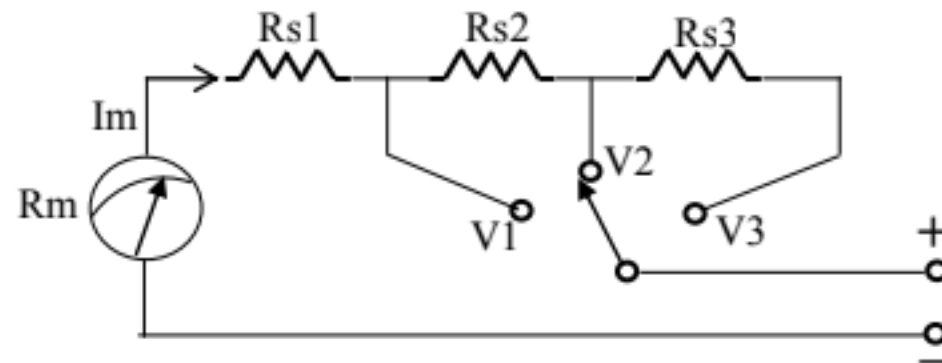

- By substituting (1) in (2), we get;

$$V_2 - \left(\frac{V_1 - R_m I_m}{I_m} \right) * I_m - R_{s2} I_m - R_m I_m = 0$$

$$V_2 - V_1 + \cancel{R_m I_m} - R_{s2} I_m - \cancel{R_m I_m} = 0$$

$$R_{s2} I_m = V_2 - V_1$$

$$\Rightarrow R_{s2} = \frac{V_2 - V_1}{I_m}$$

- Using the same steps above, we can get;

$$R_{s3} = \frac{V_3 - V_2}{I_m}$$

Example7:

let us look at the figure below. It shows a DC voltmeter whose range is extended using the Indirect Method. If we wanted to calculate R_{s5} , then we can write;

Sol:

$$R_{s5} = \frac{V_5 - V_4}{I_m}$$
$$= \frac{500 - 250}{100 * 10^{-6}} = 2.5M\Omega$$

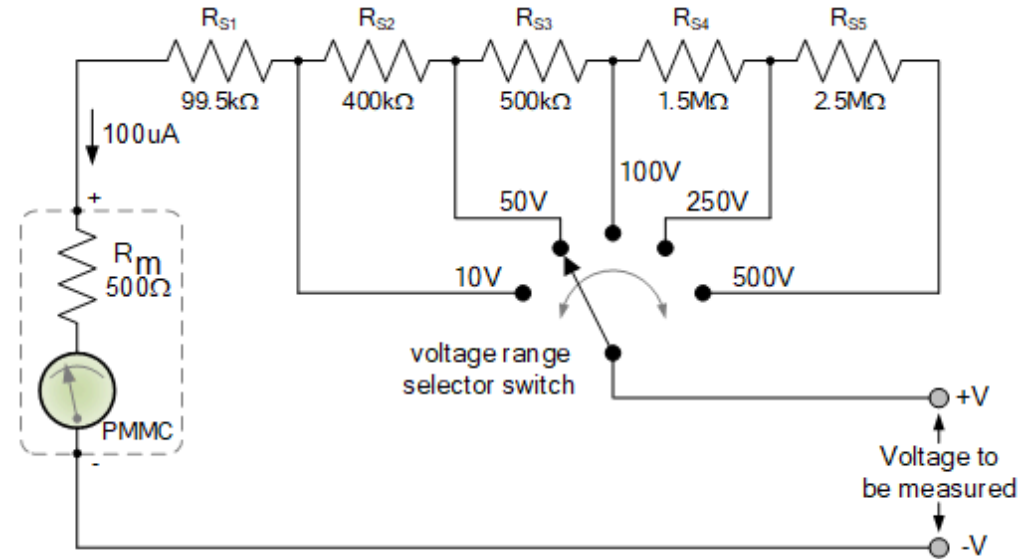

Quiz

Answer all question given in the Quiz assignment